

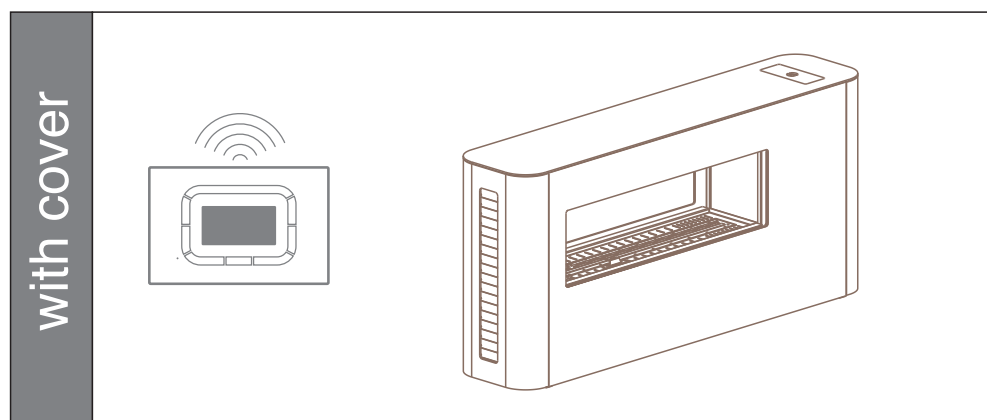

Italkero

Gas heating

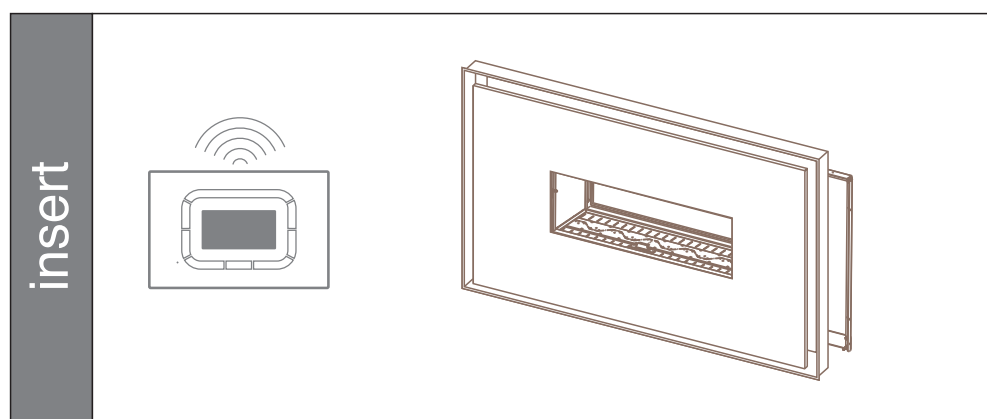

FIREPLACE

forced draught

USER, INSTALLATION, TECHNICAL SUPPORT



0476
CR1227

CONFORMITY

Our equipment is conforming with:

- Regulations (UE) 2016/426 (GAR)
- Electromagnetic Compatibility Directive 2014/30/UE
- low Voltage Directive 2014/35/UE
- Regulations 2015/1186 Ecolabelling
- Regulations 2015/1186 Ecodesign
- Regulations RAEE 2012/19/UE



RANGE

	80	130
GRILL-LESS 1 side insert	IF08BM MQ000	IF13BM MQ000
GRILL-LESS 2 sided insert	IF08BT MQ000	IF13BT MQ000
FREE STANDING, white fireplace RAL9016	CF08BT MI300	CF13BT MI300
FREE STANDING, black fireplace RAL9005	CF08BT MI200	CF13BT MI200
PENINSULA, white fireplace RAL9016	CF08BT MP300	CF13BT MP300
PENINSULA, black fireplace RAL9005	CF08BT MP200	CF13BT MP200
1 SIDED, white fireplace RAL9016	CF08BM MW300	CF13BM MW300
1 SIDED, black fireplace RAL9005	CF08BM MW200	CF13BM MW200

WARRANTY

WORLDWIDE

Manufacturer warrants compliance of the manufacturing proceeding to EC regulations applicable to products and in force at the moment. Manufacturer warrants product free from defects in materials and workmanship. This appliance benefits of statutory warranty only if it is fitted in accordance with the Manufacturer's instructions

FOR EUROPEAN UNION ONLY

The product benefits from the European 2-year warranty throughout the product, including the electronic components; with the exception of crystals, doors, interior and general decoration, all pieces that are consumable or subject to deterioration.

Dear Technician,

Thank you for choosing our appliance which will ensure utmost well-being over time with advanced reliability, efficiency, quality and safety.

This manual will provide you with the information we feel necessary for correct and easiest installation of the appliance, without wishing to add anything to your expertise and technical ability.

Happy work and thanks again!

The manufacturer

	Define the height of the fireplace off the ground, using the adjustable feet or build an adequate base.	
	Position the appliance to define the position of the gas and electricity point.	
	Fasten the appliance to the wall or floor.	
	Install the gas system: check compliance of the supply pressure based on the values indicated in the manual and the technical data table of the appliance.	
	Install the electrical system.	
	Assembly of tubing for the fume discharge/ combustion air extraction - ensure a small slope downwards, if horizontal tubing is used. - check correct assembly and fastening the terminal (on the wall or roof)	
	Install a self-supporting covering structure independent of the appliance.	
	Position fireproof material on the covering structure. IMPORTANT! Before positioning the covering, contact the Italkero Technical Support Centre to check correct installation and operation. The Technical Support Centre cannot check correct installation, therefore it cannot obviously be responsible for any malfunctions of the appliance or hazardous situations.	
	Install the covering of the removable front panel to access the valve(only on Grill-Less models).	
	Switch on the fireplace (wood or stone) as defined in the wood and stone assembly booklet. IMPORTANT! An incorrect position of the wood or stones could obstruct correct passage of the gas and cause the glass to explode.	

GENERAL

General warnings	pag. 5
Essential safety regulations	5
Description of the appliance	6
Identification	6
Structure	7
Technical data	8
Accessories	8
Wiring diagram	9
Control panel	10

INSTALLER

Receipt of the product	11
- Dimensions and weights	12
Installation	13
- Location of the appliance	13
- Legislation	14
- Maximum double tubing length	16
- Types of installation	17
- Appliance positioning	18
- Grills GP / SDP / GPu and tubing kit	19
- Tube assembly: case A, B and C	21
- Types of installation	23
- Irradiance zone	24
- Safe distances	25
- Installation	26
- Walls protection KIT in wood	27
- Electrical connections	30
- Gas line connection	30

TECHNICAL SUPPORT

- Preliminary checks on first start-up	31
- First start-up	31
- Control unit malfunctions	32
- Checks during and after first start-up	32
- Assembly of the Wireless digital remote control	33
- Adjustments	34
- Routine maintenance	35
- Cleaning of the appliance	35
- Replacement of the components	36
- Log and river peddle KIT arrangement	40
- Maintenance	42
- Dismantling and reassembly of casing	43
- Cover adjustment	45
- Faults and solutions	46
- Useful information	48

In same parts of the book there are used these symbols:











Attention: it used to underline particular caution or actions.









Prohibited: it used to underline the actions that don't half to be executed.

GENERAL WARNINGS

-  Having remove the packaging, ensure the intactness and completeness of the content. In the event of non-compliance, contact the Agency that sold the appliance.
-  Installation of the appliance must be carried out by an authorised company pursuant to Law 5 March 1990 no. 46 which at the end of the works issues the owner with a Declaration of Conformity for state-of-the-art installation, i.e. in compliance with legislation in force and the instructions provided by the manufacturer in the installer's manual supplied with the product
-  The appliance must be intended for the use planned by the manufacturer or for which it was expressly manufactured.
All contractual or non-contractual liability is excluded on the manufacturer's side for damage caused to people, animals or property caused by wrong installation, adjustment, maintenance or improper use of the appliance.
Non-use of the appliance over a long period of time requires the following operations:
 - position the main switch of the appliance on "off";
 - position the main switch of the system, if present, "off" or disconnect the plug from the electricity socket, if present;
 - close the gas tap.
-  This manual is an integral part of the appliance and, as a result, must be carefully preserved and should ALWAYS accompany the appliance also in the event of granting to another owner or user or transfer onto another system.
-  If damaged or lost, ask the Local Manufacturer's Technical Support Service for another one.
-  The glass and frame act as a fire guard, therefore never remove them unless for maintenance and never when on. The manufacturer cannot be held in any way liable for damage caused to people, animals or property, for this type of installation fault.
-  This appliance is equipped with a firebox with embers and ceramic logs containing refractory ceramic fibre, composed of artificial silicate glass fibres. Therefore, you are reminded to contain dust release to a minimum during movement of these materials. Prolonged exposure to these materials can cause eye, skin and respiratory apparatus irritation. If one of the components of the embers or the logs needs to be replaced, you are advised to seal the removed parts in a bag and bring them to a waste disposal centre.
-  Do not use the appliance if glass is broken or with the door of the fireplace open, since this is an airtight chamber. Doing so, there is danger of leaking combustion residue and oxygen intake from the installation environment.
-  **ATTENTION! BEFORE SWITCHING ON THE APPLIANCE, READ ALL THE INSTRUCTIONS AND WARNINGS CAREFULLY CONTAINED IN THIS MANUAL.**

ESSENTIAL SAFETY REGULATIONS

Remember that use of the products that use fuel and electrical energy require compliance with certain essential safety regulations, such as:

-  It is forbidden for children and incapable people from using the appliance.
-  It is forbidden to activate electrical devices or appliances such as switches, household appliances, etc. if there is a smell of fuel or from combustion or unburnt fumes.
In this case:
 - ventilate the premise by opening the doors and windows;
 - close the shut-off device of the fuel;
 - regular intervention of the manufacturer's Technical Support Service or professionally qualified staff.
-  It is forbidden to touch the appliance in bare feet and with wet body parts.
-  Any cleaning intervention is forbidden before completely cooling the appliance, therefore disconnect from the electrical power mains by positioning the main switch of the system "OFF" or disconnect the plug (if present).
-  It is forbidden to pull, detach, twist electric cables exiting the appliance even if it is disconnected from the electrical mains.
It is forbidden to position objects on the appliance such as towels, dishcloths, doilies, etc. that could cause malfunctions or also danger.
-  It is forbidden to dispose of or leave packaging material within children's reach (cardboard, staples, plastic bags, etc.) since it could be a source of danger.

DESCRIPTION OF THE APPLIANCE

They are independent gas appliances for ambient heating.

They use a burner with forced combustion TYPE C12 - C32 - C42 - C52, airtight to the environment in which they are installed, a maximum guarantee of safety since fumes from the discharge or fuel cannot be released into the ambient premises.

Extraction of combustion air and discharge of combustion products take place outside the installation environment.

Given their contained dimensions, they can be installed in limited spaces and to ensure greater well-being in the heated ambient.

The forced convective motion allows rapid heating of the environments when heating is requested.

An electronic board controls all the main functions of the appliance and automatically shuts off gas supply in the event of a fault.

The control panel allows: On/Off power supply of the appliance, start and stop in manual or automatic mode, Wireless On/Off, select the thermal power, adjust the ambient temperature and restore the operating conditions after a possible fault

⚠ The appliances are prepared, in the factory, for Methane GAS operation, but they can also be ordered for LPG operation (G30/G31). This appliance can be transformed from Methane to LPG and vice versa, replacing the burner unit.

The type and pressure of the gas used for operation are indicated on the technical data plate applied on the appliance.

Do not modify the default settings of the gas control unit or the receiver before installation. The burner is calibrated in the factory by the manufacturer.

The fireplace must be connected to the gas type indicated on the burner. Never connect a Methane burner to LPG or vice versa.

IDENTIFICATION

The appliance can be identified via:

- the packaging label

bearing the name of the product, the code, the serial number and the type of gas usable.

- the Technical Data Plate

bearing the serial number, the model and the main technical-performance data.

- The gas setup plate

Bearing the name of the gas for which the appliance was prepared and adjusted. If proceeding with a gas transformation, this plate must be replaced with the new gas plate!

⚠ Spare parts and/or technical interventions require the exact identification of the appliance model on which they are intended. Tampering with, removal of or missing technical plate or anything else does not allow safe identification of the product making any installation or maintenance operation difficult.

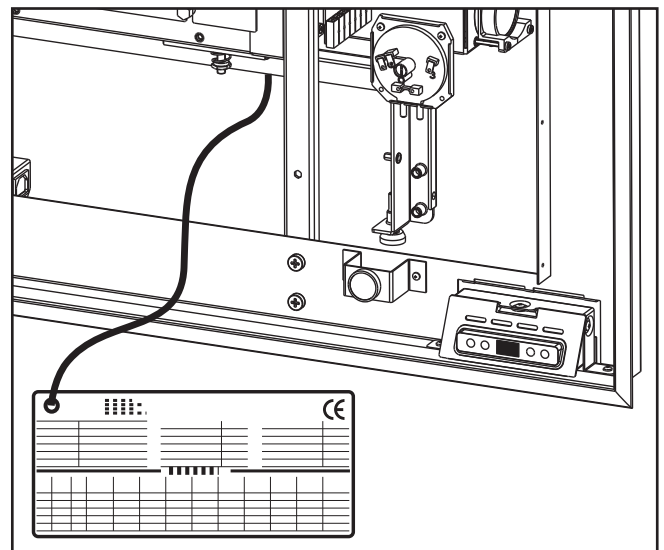
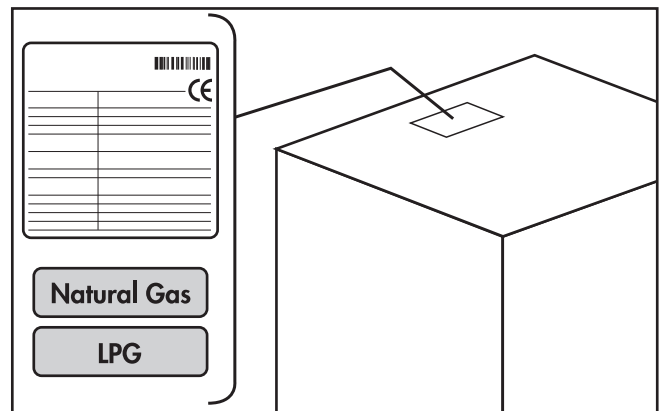

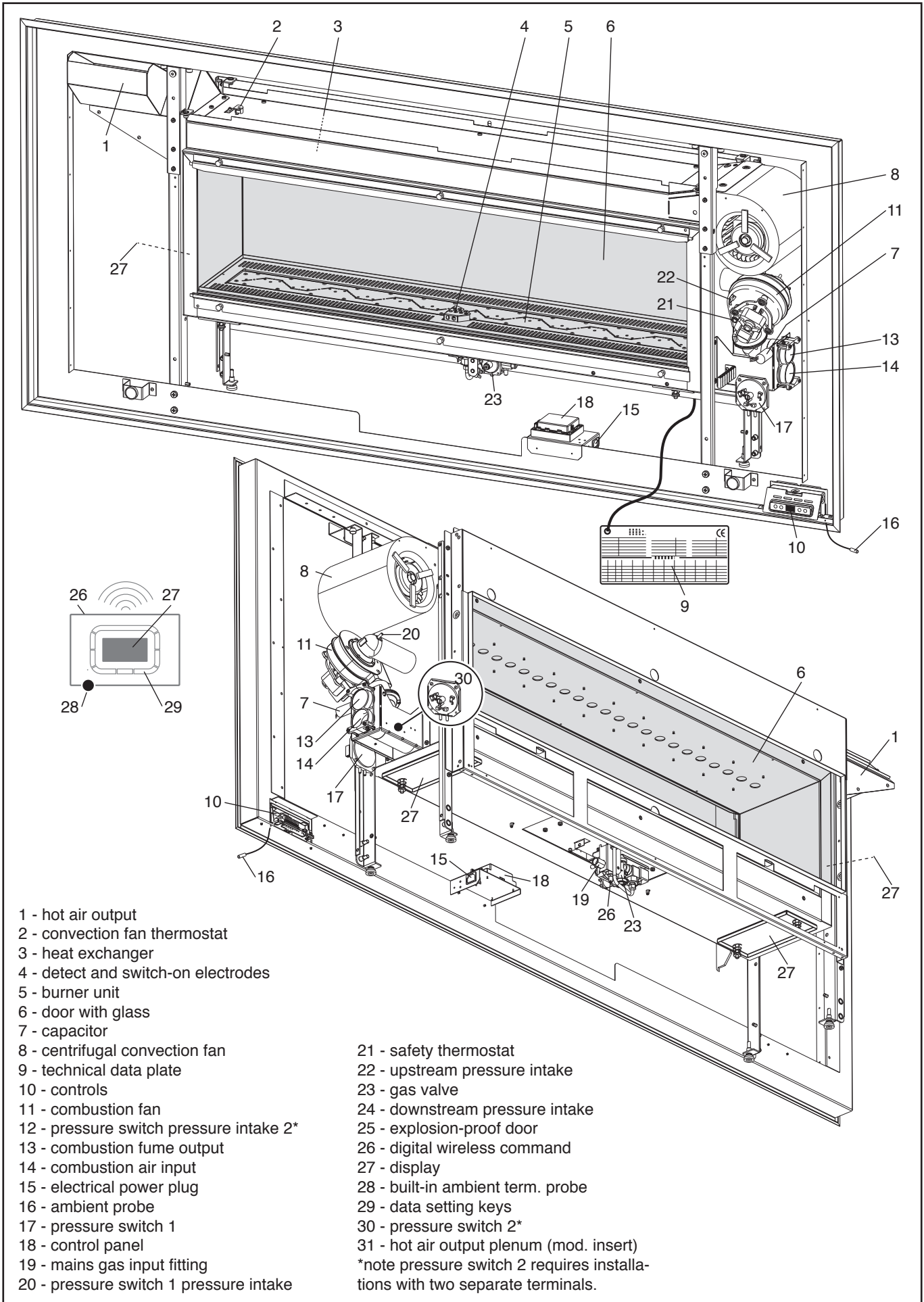

- 1 - hot air output
- 2 - convection fan thermostat
- 3 - heat exchanger
- 4 - detect and switch-on electrodes
- 5 - burner unit
- 6 - door with glass
- 7 - capacitor
- 8 - centrifugal convection fan
- 9 - technical data plate
- 10 - controls
- 11 - combustion fan
- 12 - pressure switch pressure intake 2*
- 13 - combustion fume output
- 14 - combustion air input
- 15 - electrical power plug
- 16 - ambient probe
- 17 - pressure switch 1
- 18 - control panel
- 19 - mains gas input fitting
- 20 - pressure switch 1 pressure intake

- 21 - safety thermostat
 - 22 - upstream pressure intake
 - 23 - gas valve
 - 24 - downstream pressure intake
 - 25 - explosion-proof door
 - 26 - digital wireless command
 - 27 - display
 - 28 - built-in ambient term. probe
 - 29 - data setting keys
 - 30 - pressure switch 2*
 - 31 - hot air output plenum (mod. insert)
- *note pressure switch 2 requires installations with two separate terminals.

TECHNICAL DATA

Technical data	u.m.	80		130	
		IF08BM IF08BT CF08BM MW CF08BT MP CF08BT MI		IF13BM IF13BT CF13BM MW CF13BT MP CF13BT MI	
Model 1 side					
Model 2 sided					
Model wall					
Model peninsula					
Model free standing					
Supply	-	methane	LPG	methane	LPG
		G20	G31	G20	G31
Nominal heat input. (Qn)	kW	5,6	5,6	9,0	9,0
Red. heat input.	kW	4,3	4,3	7,0	7,0
Nominal heat output (Pn)	kW	4,99	4,99	8,14	8,14
Red. heat output	kW	3,7	3,7	6,1	6,1
Efficiency	%	89,2	89,2	90	90
Nominal supply pressure	mbar	20,0	37,0	20,0	37,0
Nominal nozzle pressure	mbar	12,0	36,8	12,0	36,8
Reduced nominal nozzle pressure	mbar	7,0	20,0	7,3	20,0
Gas consumption (15°C) Nom./Red.	m ³ /h kg/h	0,592/0,454	0,435/0,334	0,952/0,739	0,689/0,543
Type of appliance		C12 - C32 - C42 - C52			
Fuel category		I 2H	I 3P	I 2H	I 3P
Efficiency class / NOx		1 / 5	1 / 5	1 / 5	1 / 5
Burner nozzles	nr mm	1 1,98	1 1,10	2 1,90	2 1,05
Pilot nozzles	nr Code	1 35	1 25	1 35	1 25
Power supply: 3 batteries A	V -	230			
Power input in operation	W	92			
Degree of protection	-	IPXXB			
Gas connection pipe	-	Ø 10mm			
Gas valve to burner supply pipe	-	Ø 8mm			
Intake/exhaust pipes	Ø mm	54/54 or 80/80(optional)			
Batteries					
- Remote control	nr	2 x 1,5V AAA			

ACCESSORIES

DESCRIPTION
Ø54 - Elbow 90° pipe union
Ø80 - Elbow 90° pipe union
Ø54 - Pipe L = 500mm
Ø80 - Pipe L = 500mm
Ø54 - Pipe L = 1000mm
Ø80 - Pipe L = 1000mm
Ø54 - Elbow 90° cast
Ø54 - Elbow 135° pipe union
Ø80 - Elbow 135° pipe union
Adapter connection from Ø54 to Ø80
Ø54 - Insulating L = 1000mm (4 pcs.)
Ø54 - Intake or exhaust singol terminal
Ø80 - Intake or exhaust singol terminal
Ø54 - Intake and exhaust unique terminal
Ø54 - Special outlets kit
Ø54 - Grille for singol terminal "GP"
Ø54 - Grille for singol terminal "GPu"
Ø54 - Grille for unique terminal "SDP"
Ø54 - Chimney
Ø80 - Chimney
Ø54 - Chimney sloping roof
Ø90 - Chimney flat roof
Kit gas tap connection
Protection kit for wooden walls
Ø54 - Coaxial kit for roof installation

FUNCTIONAL WIRING DIAGRAM

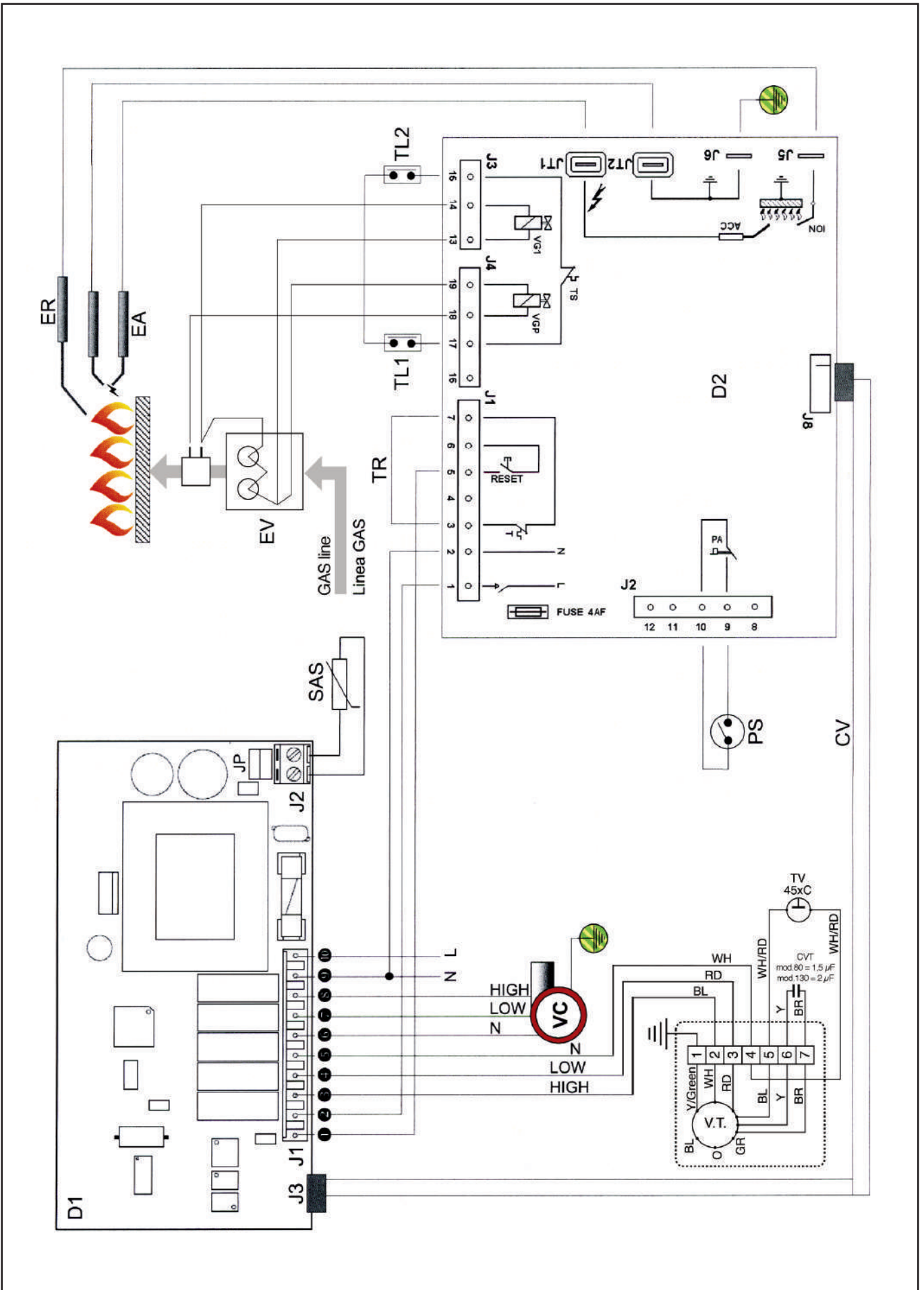

CONTROL PANEL

- 1 - On/Off key and device RESET
- 2 - Reduce temperature key (MIN 5°C)
- 3 - Light display
- 4 - Increase temperature key (MAX 35°C)
- 5 - Enable/disable Wireless command key

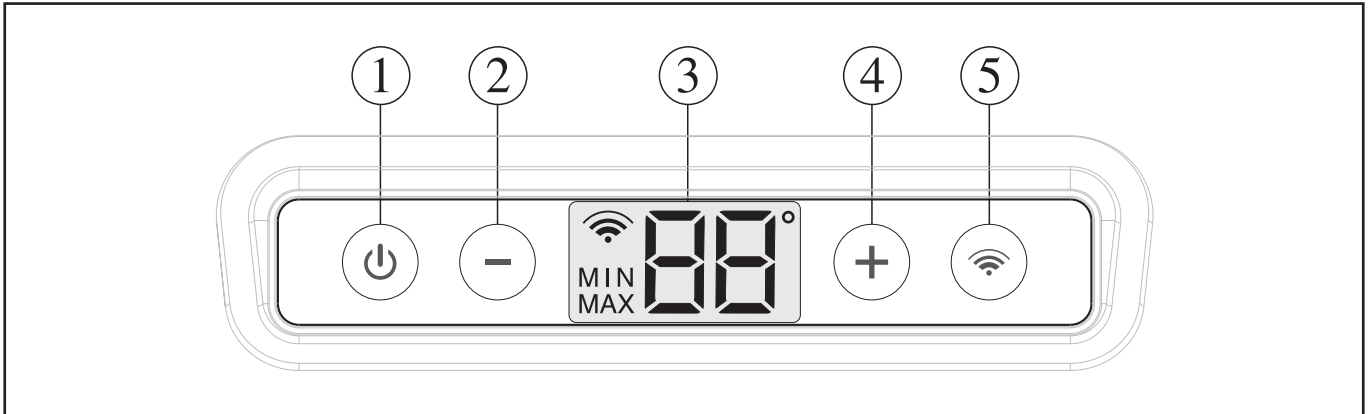

DESCRIPTION OF DISPLAY

This type of screen simultaneously provides an entire series of information:

- MIN operating power.
- MAX operating power.
- Wireless command enabling.
- ambient temperature.
- desired ambient temperature.
- degrees centigrade unit scale.
- data transmission

DESCRIPTION OF ICONS

- 1 - operation at MAX power.
- 2 - operation at MIN power.
- 3 - data transmission between the appliance and the Wireless command (intermittent icon).
- 3b - Wireless command enabled (fixed on icon).
- 4 - Detected ambient temperature.
- 4b - Desired ambient temperature.

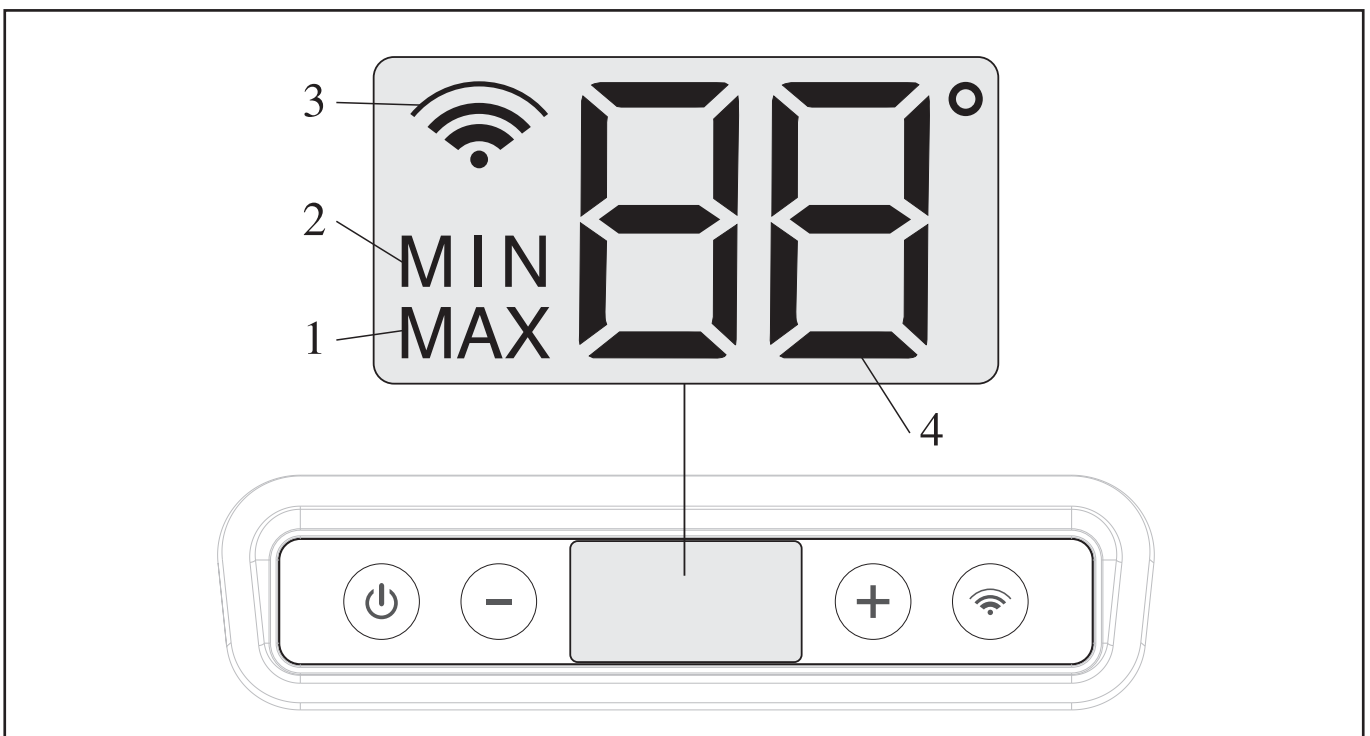

The appliance is provided with:

- no. 1 Appliance
- no. 1 Glass cover
(*not for GRILL-LESS models)
- no. 1* Wall protection rear screen (*standard only
on single face models)
- no. 1* Fitting to channel warm air (*standard on fit
ted insert models)
- no. 1 Standard manual command
- no. 1 Wireless command
- no. 1 Envelope with documents:
 - no. 1 Instruction manual for user
 - no. 1 Manual for installer
 - no. 1 Certificate of warranty
 - no. 1 Warranty label

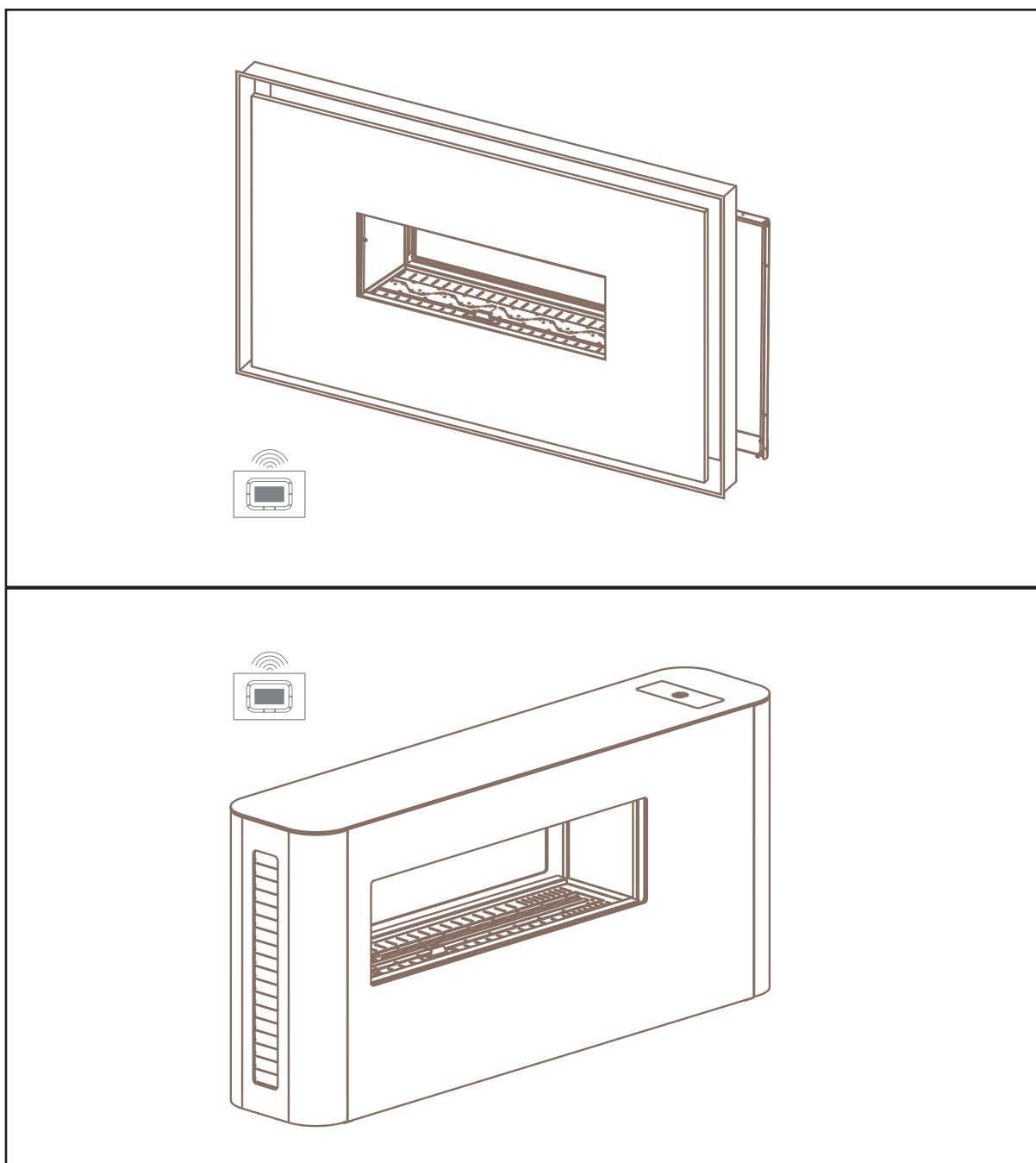

DIMENSIONS AND WEIGHTS

To install this appliance, TUBING must be installed most suitable for the type of combustion air extraction and fume discharge you intend installing.

The manufacturer provides all the accessories necessary, proposing different technical and aesthetic solutions for customisation of the various models.

- 1) Fireplace insert.
- 2) Fireplace with glass casing.
- 3) Plasterboard support structure

Legend:

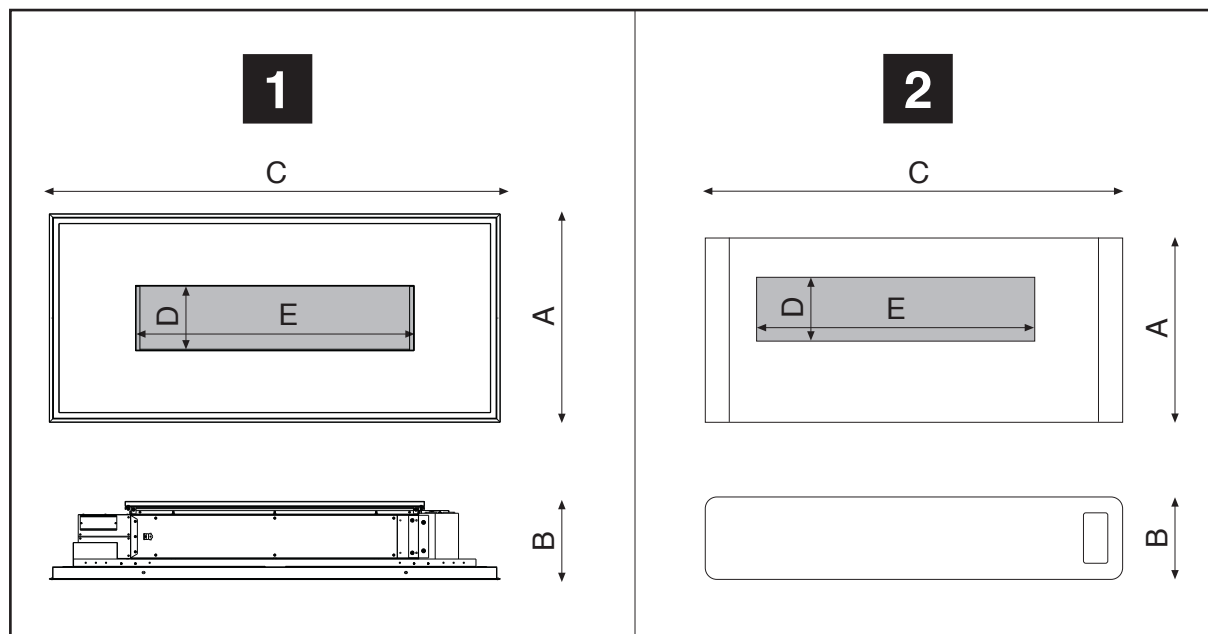

	1		2		
	<i>mod. 80</i>	<i>mod. 130</i>	<i>mod. 80</i>	<i>mod. 130</i>	
A	1027	1027	820	820	<i>mm</i>
B	380	380	370	370	<i>mm</i>
C	1689	2220	1480	2012	<i>mm</i>
D	318	318	285	285	<i>mm</i>
E	836	1370	767	1300	<i>mm</i>
Net weight front	145	183	-	-	<i>Kg</i>
Net weight tunnel	144	170	-	-	<i>Kg</i>
Net weight freestanding	-	-	150,5	259	<i>Kg</i>
Net weight peninsula	-	-	144	252,5	<i>Kg</i>
Net weight wall	-	-	136,5	239	<i>Kg</i>

GENERAL INFORMATION

This appliance is airtight to the environment in which it is installed therefore the combustion air is extracted only from outside!

- do not use for positioning, accessories or components not planned by the manufacturer, which could create serious danger.
- do not place the power supply cable on hot surfaces for example air diffusion grates or fume discharge tubes.

it is compulsory for the installer, following assembly, to inform the user on the behaviour to maintain during appliance operation:

- do not place curtains, towels and similar items on top that could cause malfunctions and danger to obtain good air recirculation in the environment.
- do not block the appliance intake/discharge terminal with hanging linen or rugs.

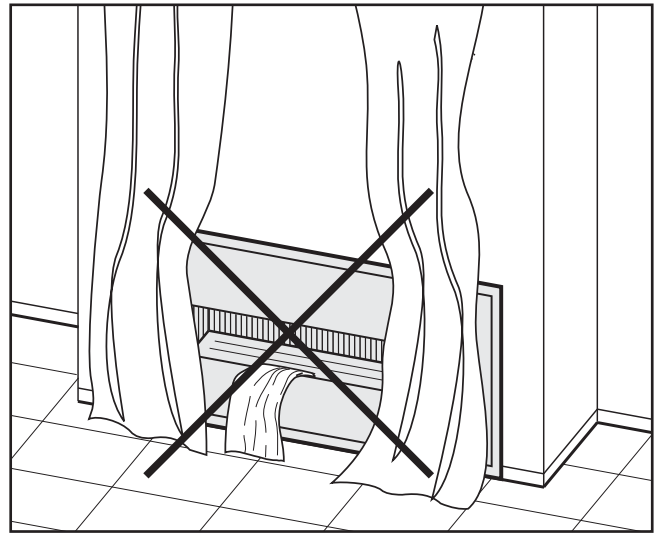

LOCATION OF THE APPLIANCE

Installable in any type of premises with the exception of garages, warehouse where fuel or flammable materials are stored. the installation environment does not require openings for ventilation, however it must be ventilated with doors or windows communicating with outdoors which can open.

⚠ For lpg appliances, all premises are excluded that have floor under the treadable outside flooring or communicating with this type of environment

Before proceeding with masonry works, check the adequate support capacity of the floor and that there is sufficient space to ensure correct operation of the gas appliance as well as its maintenance. Check there are no wooden slats, plastic material or other material not resistant to heat, which could come in contact with the fume discharge tubing.

⚠ Before fastening the tubing, insulate the fume discharge tubing, with resistant materials for high temperatures (e.g. ht- armaflex).

⊘ It is forbidden to install the appliance within the buffer zones of the baths or near the water supplies. these particular installations require special guards in compliance with electrical safety standards in force. Safety in force.

Gas supply

good operation of the appliance is also subordinate to the dimensions of the tubing:

- see uni7131 4.1.1 with App. A
- see uni7129 3.1 with App. A.

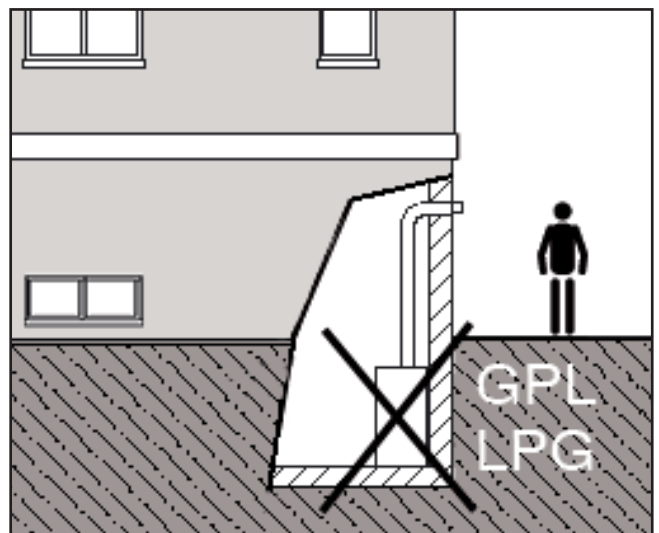

DOUBLE TUBING MAX LENGTH
(Ø54 and Ø80 mm)

 Before proceeding with installation of the appliance, you are advised to have an inspection carried out by qualified staff. Positioning of the discharge and the tubing for balanced flow appliances are regulated by standard UNI 7129.

All balanced flow products are “CE certified at European level.

NOTE: the number of curves is intended as the overall number of curves used.

NOTE: the linear length is intended as the sum of all the straight horizontal and vertical sections.

NOTE tubing Ø54: only for mod. milano130, the values in the table must be halved for correct operation of the appliance.

NOTE tubing Ø80: the values in the table can be used for all models.

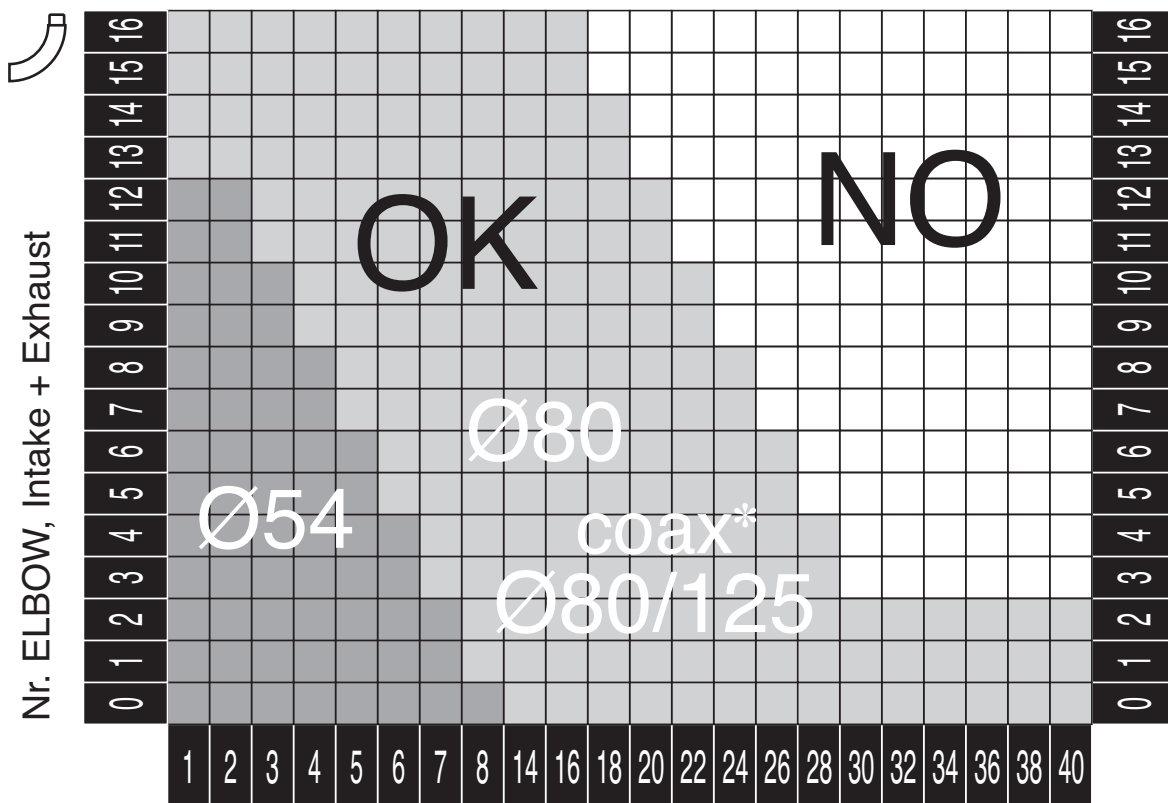

LINEAR LENGTH, Intake + Exhaust
exp. 20 + 20 m or 39 + 1 m



Installation phases

Installation phases of APPLIANCE are:

- choice of appliance location
- assembly of the fume discharge and combustion air extraction tubing (With **One** terminal or two **Singles**)
- installation of the APPLIANCE
- electrical connections
- gas line connection

TYPES OF INSTALLATION ACCORDING TO CIG 7129

Below, the types of installation of the tubing are represented (extraction and discharge) according to the instructions of the standard UNI CIG 7129 in force, for the products that have the following construction and installation characteristics.

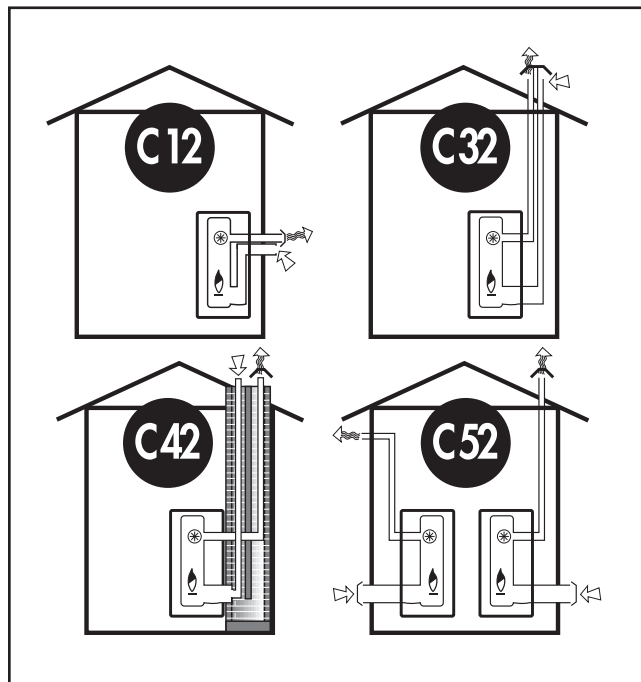

ASSEMBLY OF TUBING FOR THE FUME DISCHARGE AND COMBUSTION AIR EXTRACTION

The extraction and discharge tubing can be installed fitted in walls or in view. In the latter case, they must be adequately protected and anchored to avoid hazardous conditions. If you decide to install the extraction and discharge tubing under the floor, you must:

- insulate the tubing.
- install the tubing at a depth to ensure the fume heat cannot affect the floor.
- create an inspection system to allow possible cleaning or replacement of the tubing under the floor.

Remember to ALWAYS insulate the DISCHARGE tubing (to avoid condensate formation) using insulated materials that resist high temperatures (e.g. HT-/Armafex).

Drill fastening holes of the tubing only after establishing their length and having inserted them in the correct position.

Before carrying out assembly of the tubing **check both the MAX length of the tubing and the MAX permitted load loss are met** (see Table).

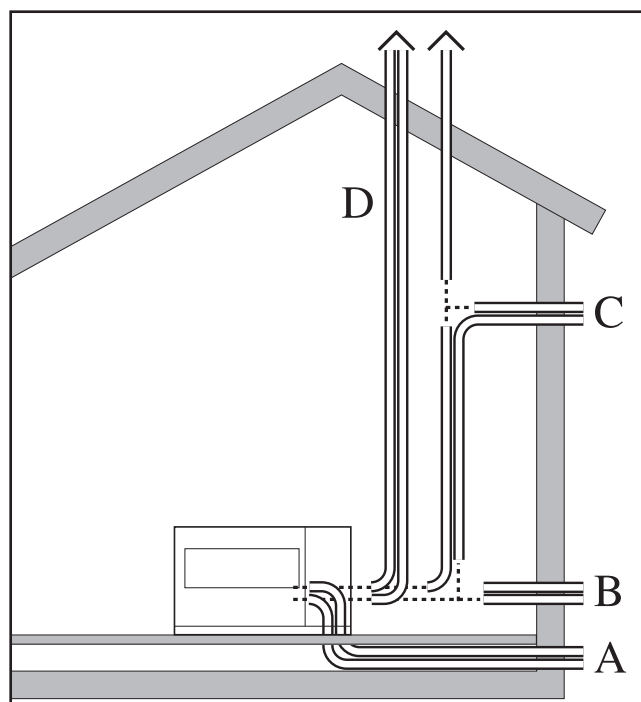

	80	130	
Ø unloaded intake tubes	54	54	mm
Ø Wall hole single terminal tubes	110	110	mm
MAX single terminal tube length	10	10	m
MIN comprehensive tube length	1	1	m

	80	130	
Loaded loss tube l= 500 mm	1,2	2,8	Pa
Loaded loss tube l= 1000 mm	2,3	5,6	Pa
Loaded loss tube curve 90°	2,2	4,5	Pa
Loaded loss single terminal	4,0	5,0	Pa
Loaded MAX loss permissible (*)	50	46	Pa

(*) - Sum of the pressure leak both air suction and gas exhaust pipes.

APPLIANCE POSITIONING

To establish the position of the APPLIANCE:

- mark and make the centring hole (1), crossing the entire thickness of the wall;
- make a tubing passage hole (extraction and discharge), using the centring hole (1);

Hole Ø 110 mm for tubing Ø 54 mm.

⚠ To avoid damaging the outer part of the wall to perforate, you are advised to make the hole in two phases: starting inside (A) and terminate on the outer part (B).

- cut the tubing to measure the thickness of the wall adding 25 mm, then eliminate the excess parts.

⚠ **The cut must be perpendicular to the axis of the tubes, paying utmost attention not to deform them. After cutting, carefully remove all burrs.**

To facilitate assembly of the tubes with O-Rings, use silicone grease or a soapy solution and check the O-Rings do not exit their compartment.

- insert and fasten any curves and tubing (2) on the group (3);
- with the help of a level, check correct horizontal and vertical inclination of the tubing group;
- insulate the discharge (4) and insert the tubing in the hole in the wall;
- check perfect sealing of the system and complete installation.

⚠ **Before fastening the tubing, insulate the fume discharge tubing, with resistant materials for high temperatures (e.g. HT/- Armaflex).**

⚠ **In the event of replacement or addition of any component, only use Original Accessories and Spare Parts provided with a certificate by the manufacturer.**

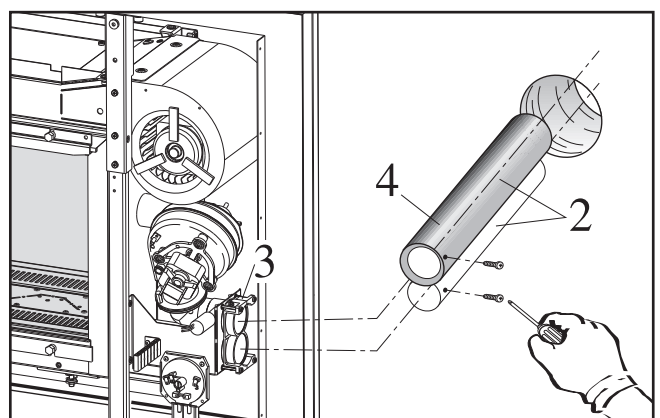
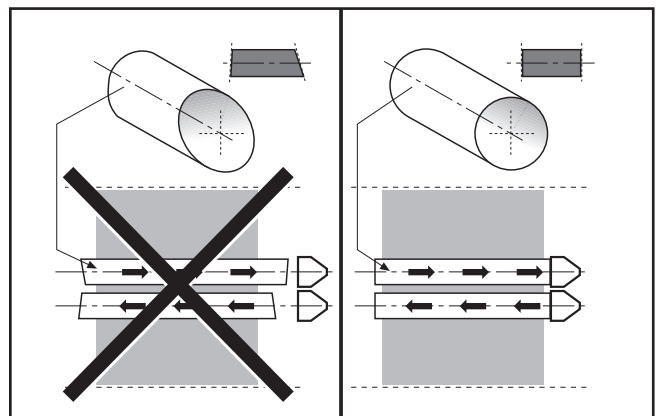
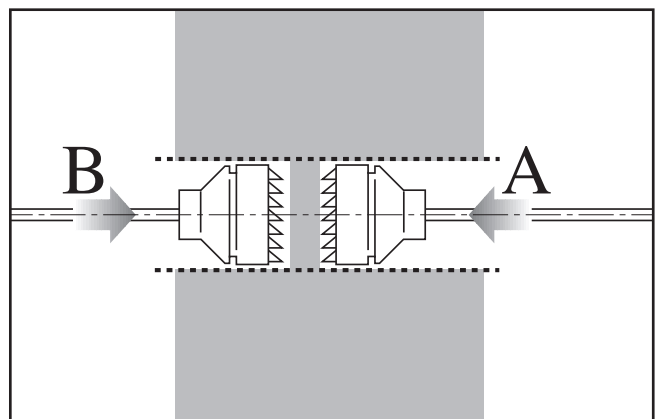
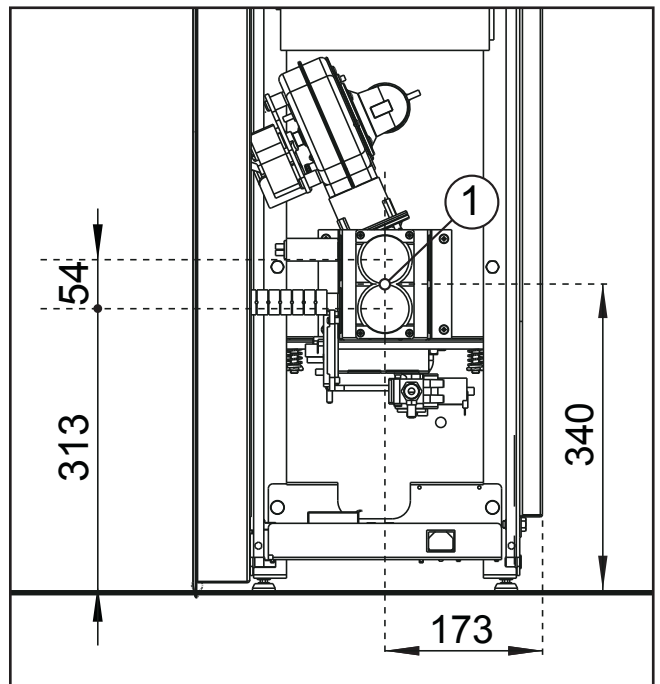

Assembly of external “GP” grates only for SINGLE terminals (Code 700000350)

Assembly of the GP protective grid is created by fastening it (centring it compared to the terminal) with plugs on the wall and/or together with the flange in stainless steel.

Assembly of “SDP” fitted screens for SINGLE terminals (Code 700000365)

Assembly is carried out as follows:

- Having made the hole (centred compared to the hole of the tubing) on the external wall, fit the screen completely, setting it in the wall with mortar.
- Assemble the tubing on the terminal, fastening it with the screws supplied.
- Adapt the length of the tubing with the terminal at the wall thickness, between the inner wall and the grate of the screen.

The cut must be perpendicular to the axis of the tubes, paying utmost attention not to deform them. After making the cut, carefully remove the burrs and make the fastening holes.

TUBING KIT Ø 54mm PARALLEL WITH ONE TERMINAL (STANDARD)

These kits use parallel tubing and are indicated when the fumes discharge and the combustion air extraction are near the appliance.

Assembly of tubing and one terminal from OUTSIDE

- Insert the assembled unit, tubing, any corner curves, in the wall.
- position the extraction/discharge tubes flush to the external wall.
- connect the one terminal in the tubing, adhering the washer on the wall.
- mark with a flat heat punch the fastening hole centres.
- remove the terminal, drill the holes with a Ø 6 mm bit to host Ø 6 mm plugs.
- fasten the one terminal to the wall using the Ø 6 mm plugs supplied, paying attention the **fume discharge hole of the terminal is completely positioned upwards**.

⚠ Ensure correct insertion of the tubing in the adaptor fitting.

To facilitate assembly of the tubes with O-Rings, use silicone grease or a soapy solution and check the O-Rings do not exit their compartment.

⚠ **Before fastening the tubing, insulate the fume discharge tubing, with resistant materials for high temperatures (e.g. HT/-Armaflex).**

⚠ **Do not lean the appliance on the wall to facilitate correct assembly and dismantling of the casing, always leave 10mm MIN.**

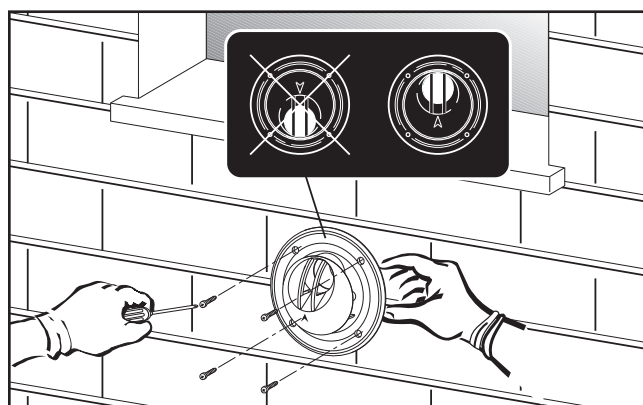
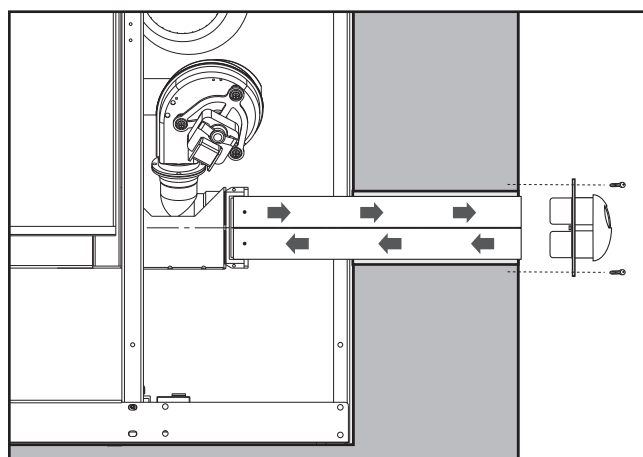
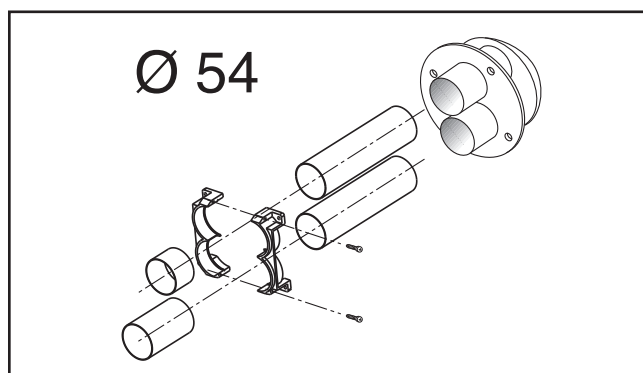
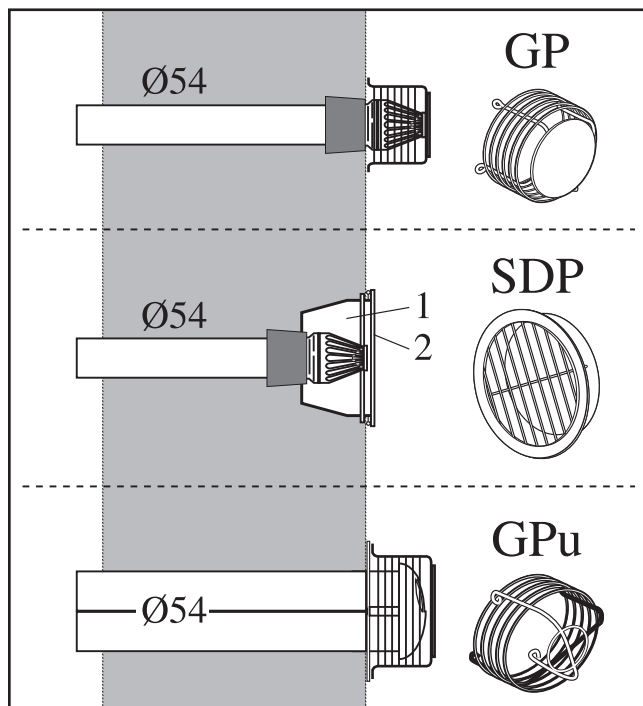

Assembly of the SPECIAL TUBING KIT from inside the premises to heat

Having made the hole in the wall, adapt the length of the SPECIAL KIT tubing to the actual thickness of the wall, cutting the excess part. **IMPORTANT:** the tubing must be cut strictly perpendicular to the axis of the tubing, paying utmost attention not to deform the tubing.

Before inserting the hole made in the wall, fasten the SPECIAL KIT on the adaptor fitting with the screws supplied.

Insert the assembled "group" in the hole (SPECIAL kit + adaptor fitting).

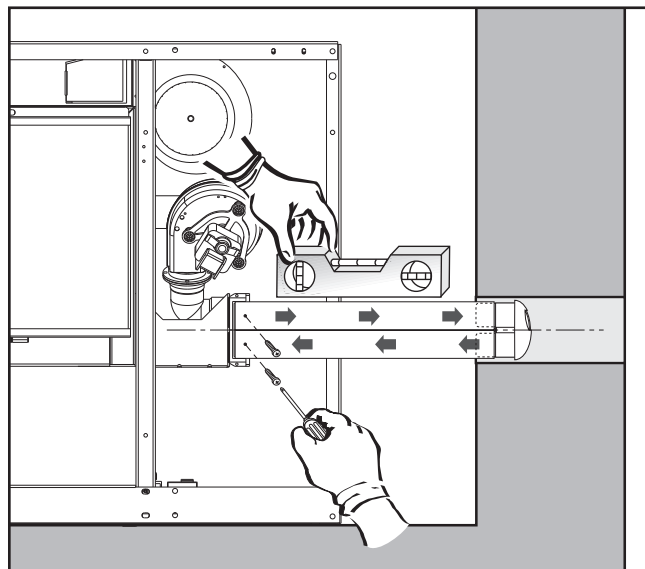

TUBING KIT Ø 54mm WITH SINGLE TERMINAL (SPECIAL)

This kit uses separate tubing and are indicated when the fumes discharge and the combustion air extraction are far from the appliance.

The types of installation can be the most varied, but can be traced back to the three examples described in this chapter.

! Before assembling the tubing kit, **check the MAX length of the tubing and the MAX load loss permitted are met** (see Table).

	80	130	
Ø unloaded intake tubes	54	54	mm
Ø Wall hole single terminal tubes	110	110	mm
MAX single terminal tube length	10	10	m
MIN comprehensive tube length	1	1	m

	80	130	
Loaded loss tube l= 500 mm	1,2	2,8	Pa
Loaded loss tube l= 1000 mm	2,3	5,6	Pa
Loaded loss tube curve 90°	2,2	4,5	Pa
Loaded loss single terminal	4,0	5,0	Pa
Loaded MAX loss permissible (*)	50	46	Pa

(*) - Sum of the pressure leak both air suction and gas exhaust pipes.

Chimney assembly

To fasten the chimney to the fume discharge and combustion air extraction tubing, use ties (1) and safety screws (2).

Application of the chimney must meet the following requirements:

- the top of the fireplace fume discharge tube must be outside the reflux zone to avoid possible counter-pressure preventing the free discharge of combustion products in the atmosphere.
- the chimney must be positioned to prevent penetration of atmospheric agents in the tubes.

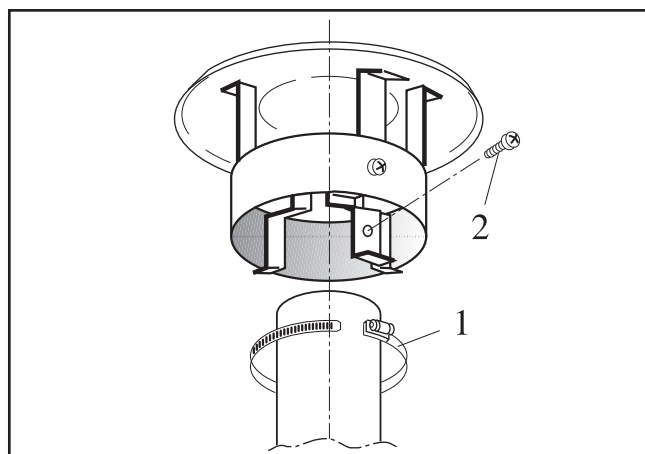

- CASES A1 and A2 - Assembly of fitted tubes, in channels, in wall.

This solution can be implemented when the thickness of the wall allows you to execute channels for tube positioning.

⚠ Before starting installation, check the minimum spaces are available for correct operation of the appliance and for its maintenance.

⚠ Before walling in the tubing, insulate the fume discharge tubing, with resistant materials for high temperatures (e.g. HT-/Armaflex).

⚠ Before assembling the tubing kit, check the MAX length of the tubing and the MAX load loss permitted (see Table).

For installation of the fume discharge and air extraction tubing:

- level, mark and make the hole for tubing passage.
- make the channels in the wall to host the curve and the tubing.
- insert and fasten any group tubing;

- Adaptor fitting - tubing group

The adaptor unit is prepared and supplied for Ø 54 mm tubing.

- Assemble the angled die cast curves (6 - only for Ø 54 mm tubing) on the adaptor fitting and fasten them in position with the screws supplied, remembering the direction of the individual tubes.
- complete installation with assembly of the remaining tubing, then cut to the tube to measure adapting it to the actual thickness of the wall increased by 25 mm.

⚠ Ensure correct insertion of the tubing in the adaptor fitting and the O-Rings do not exit their compartments, for the tubes fitted with gasket.

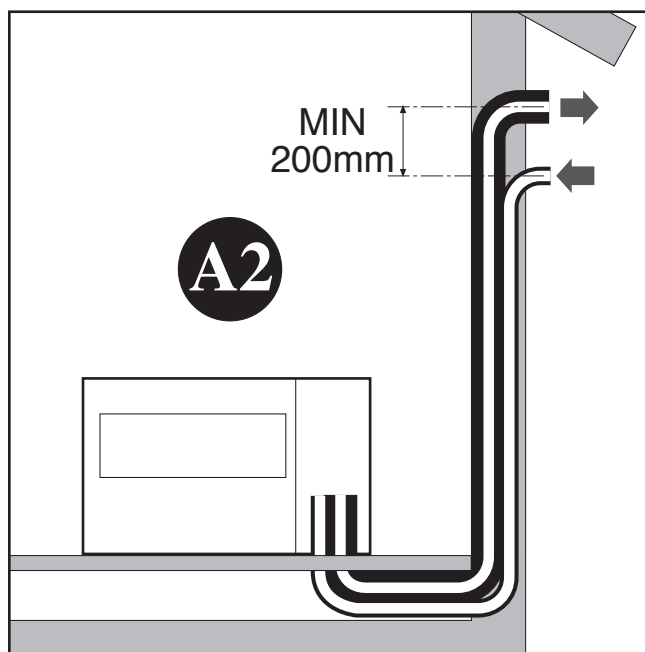
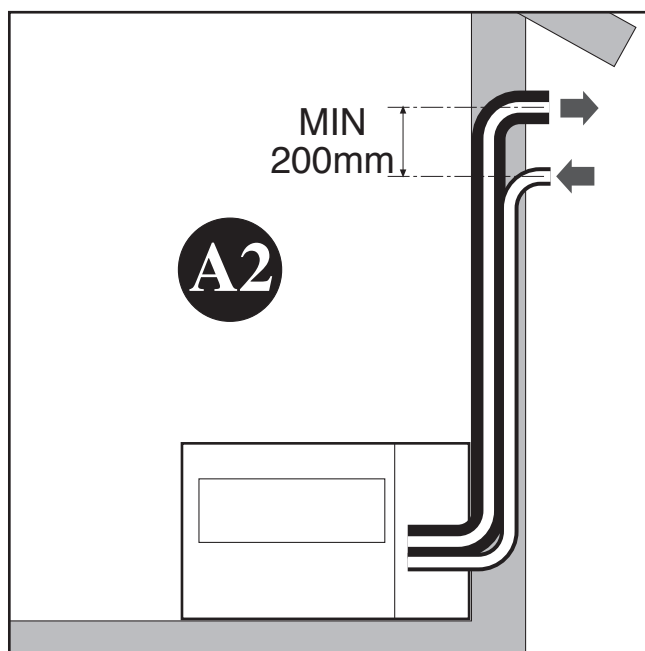
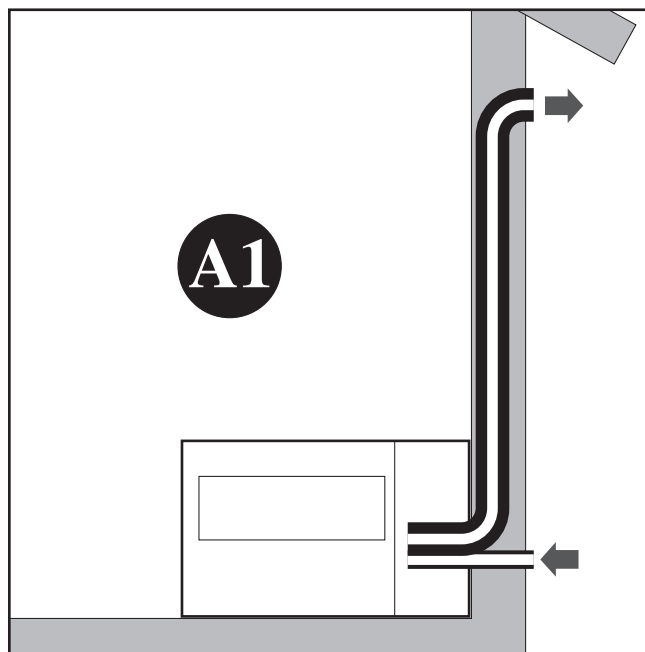
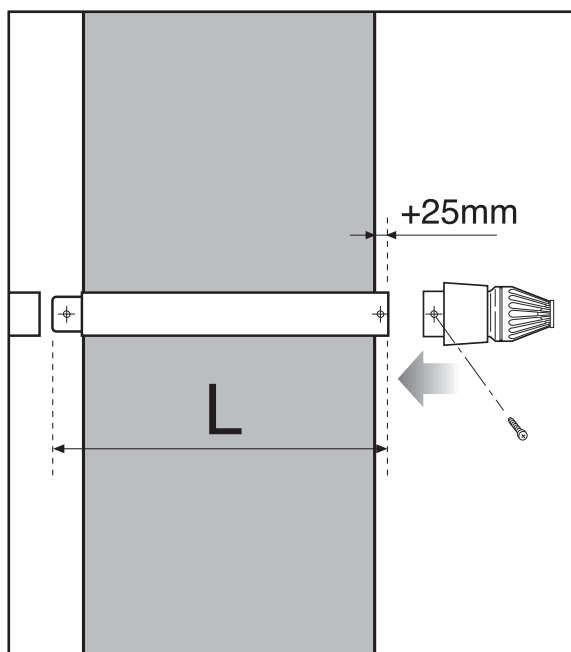

CASE B - Assembly of the tubes inside the ambient to heat

This solution can be implemented when the thickness of the walls does not allow channels to be created for the tubes.

- Follow all the various assembly phases as described in CASE A1 and A2.
- Comply with all the warnings described in CASE A1 and A2.
- Complete installation with assembly of the remaining tubes, fastening them to the wall with commercial ties.
- Install a partition wall (1) in thermally insulating material (e.g. plasterboard) to cover the tubing and isolate them from the installation environment of the appliance.

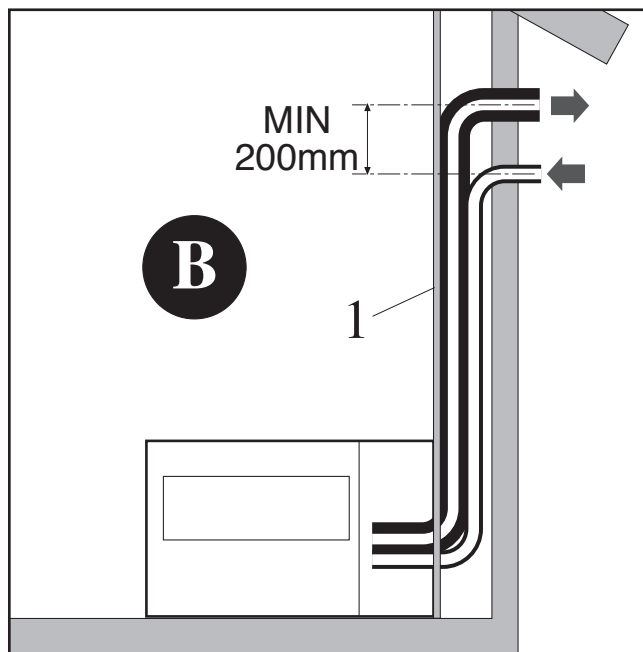

CASE C - Assembly of the tubes outside the ambient to heat

This solution can be implemented if you want to maintain the fume discharge and combustion air extraction tubing outside the ambient to heat.

- Follow all the various assembly phases as described in CASE A1 and A2.
- Comply with all the warnings described in CASE A1 and A2.
- Complete installation with assembly of the remaining tubes, fastening them to the wall with commercial ties.

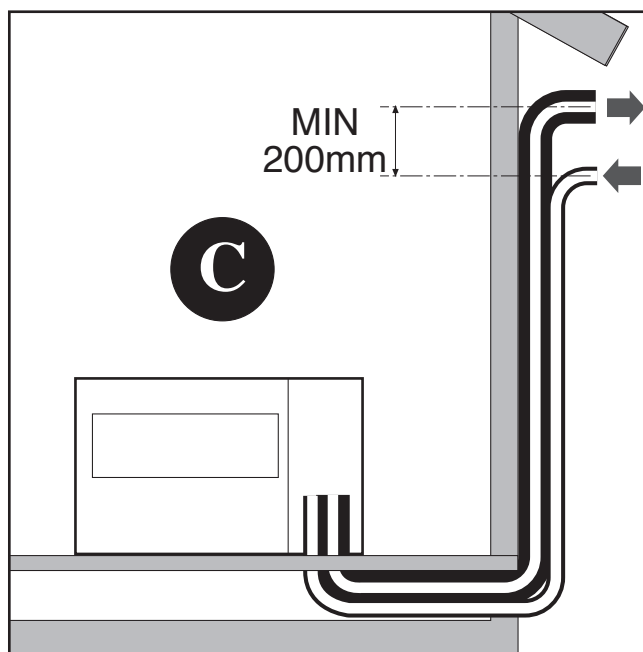
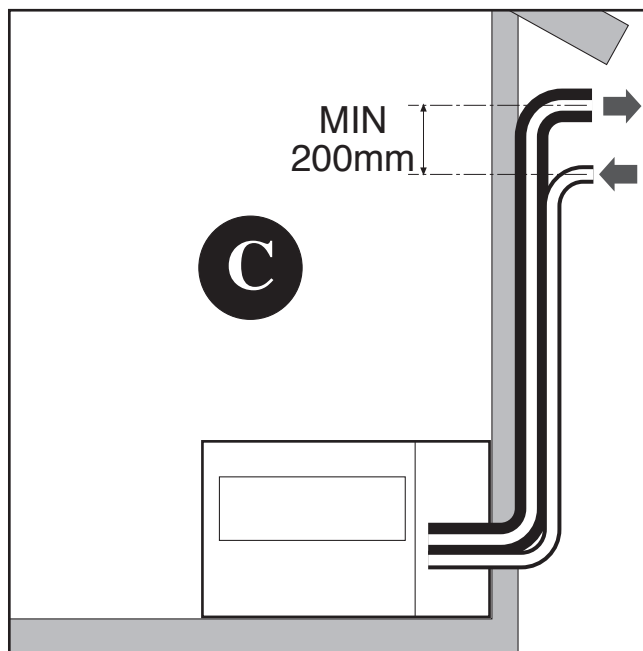

TYPES OF INSTALLATION

This appliance can offer different types of installation, in a version with casing or insert only.

- A - wall (one side).
- B - peninsula (two side).
- C - island (two side).

⚠ Fasten the appliance using plugs and brackets (not supplied nor on manufacturer's pricelist) suitable for supporting the weight and suitable for the type of wall chosen.

A - WALL, on wall (one side)

- Mod. INSERT, equipped with an insulating rear protection, it is inserted in a covering structure in non-flammable material (e.g. plasterboard (3)).
- Mod. with CASING, equipped with insulating rear protection, it is fastened to the wall.

B - PENINSULA, on a wall (tunnel)

⚠ Position the appliance with the technical compartment side (1) on the wall and the side opposite for warm air output (2) towards the ambient to heat.

- Mod. INSERT, it is inserted in a covering structure in non-flammable material (e.g. plasterboard (3)).
- Mod. with CASING, no need for insulating rear protection, it is fastened to the wall.

C - ISLAND, at the centre of the environment (tunnel)

- Mod. INSERT, it is inserted in a covering structure in non-flammable material (e.g. plasterboard (3)).
- Mod. with CASING, no need for insulating protection, it is positioned and fastened in the centre of an ambient.

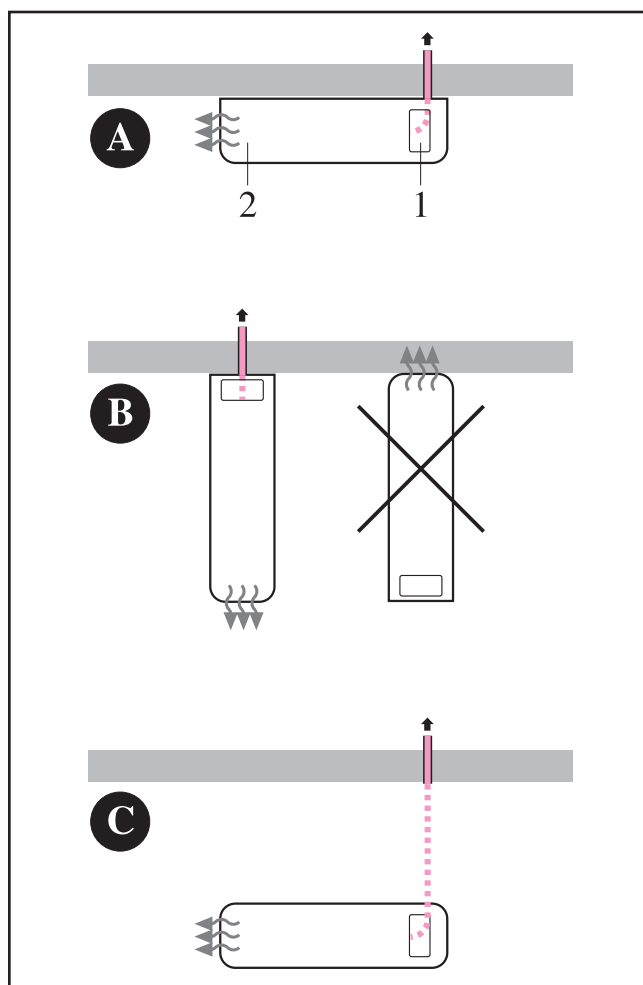
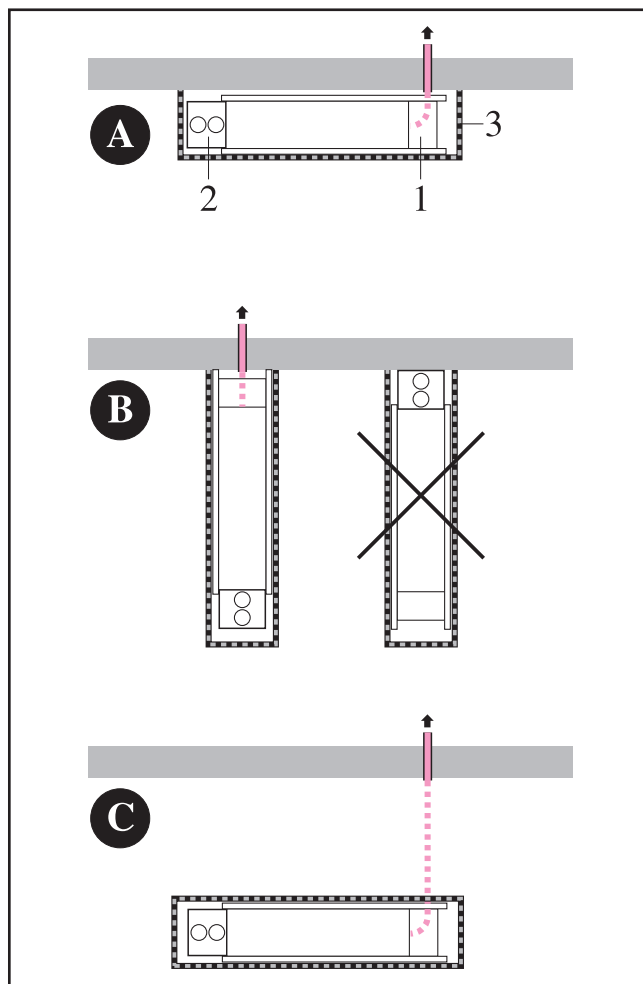

IRRADIANCE ZONE

⚠ Maintain a buffer distance of at least 1m, between the fireplace glass and the combustible/flammable objects: furniture and wooden furnishings, ornaments, curtains, etc.

Do not approach or have the fireplace glass in direct contact with combustible materials, sensitive to heat or flammable: furniture, beams, ceilings, curtains, etc.

Partition wall and decorative coating

To allow heat generated by the appliance to exit, there is no need to install openings or vents on the walls because the appliance is fitted with a frame that allows warm air to exit upwards and entry of cold air from below.

⚠ Before completing all the coating, always check: position and anchorage of the appliance, the definition of all the connections (gas and electrical) and correct operation.

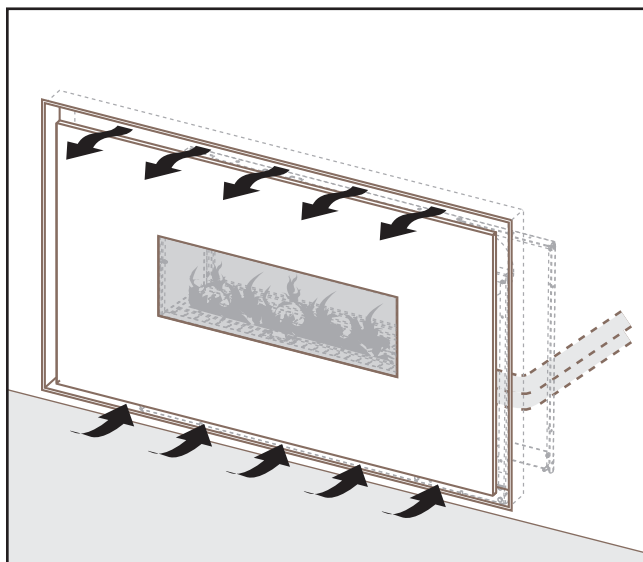
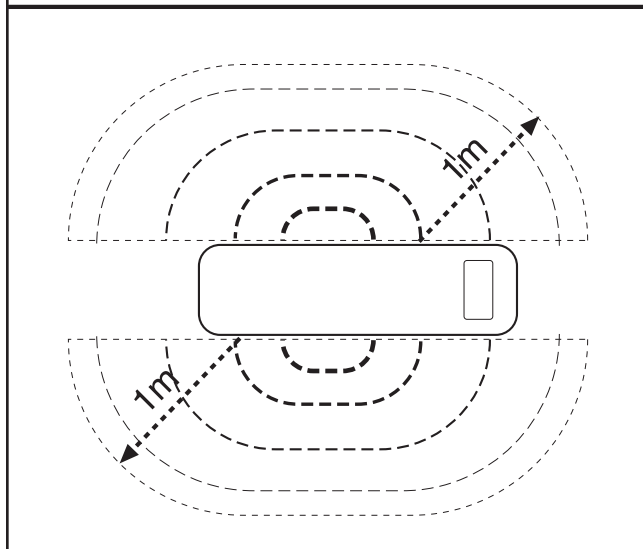
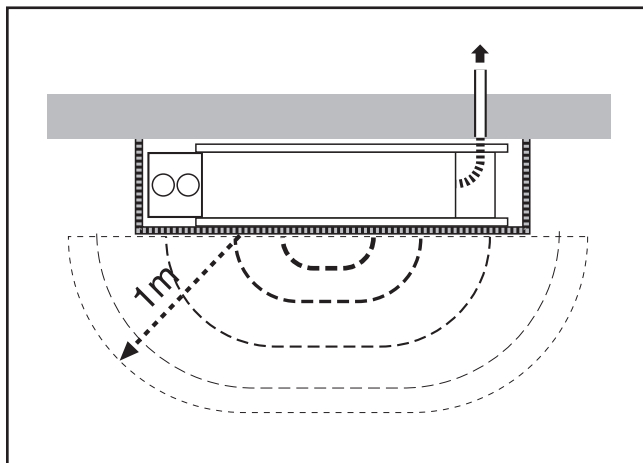

SAFE DISTANCES

- **Models with casing:** there is no need for any type of partition wall or thermal insulation, the casing covers and insulates the appliance.

- **Insert models:** thermal insulating covering required to isolate the appliance and cover it completely. For insert models only, a plenum (4) is planned that conveys warm air outwards towards the outlets.

A) FLAMMABLE WALLS

- **One side appliance:** with non-combustible partition wall and thermal insulation (1). Build a partition wall in thermally insulating material (e.g. plasterboard) 10cm thick.

⚠ Always leave an air gap of 5mm MIN between the appliance and the partition wall.

If crossing through walls, floors or roofs in material sensitive to heat or flammable, you must avoid contact with the discharge tube using appropriate thermal insulation (2) for high temperatures (shell in rockwool or glass wool etc.).

B) NON-FLAMMABLE WALLS

- **One side appliance:** without non-combustible partition wall and thermal insulation.

⚠ Always leave an air gap of 5mm MIN between the appliance and the wall.

If crossing walls in non-flammable material, you must avoid contact with the discharge tube using specific insulation tubing (3).

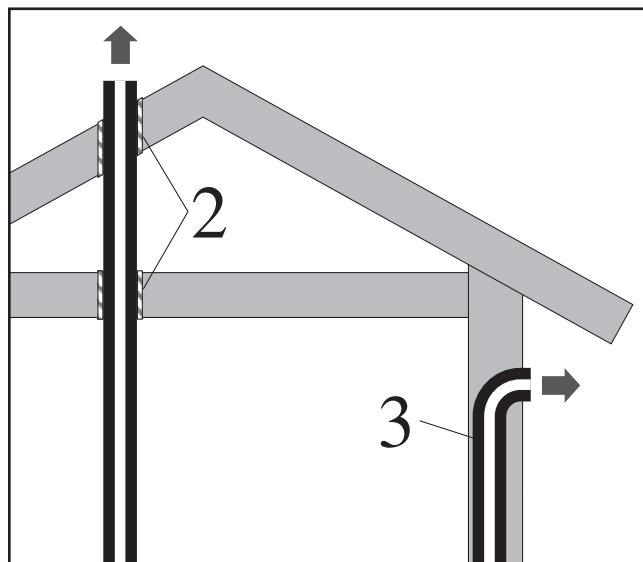
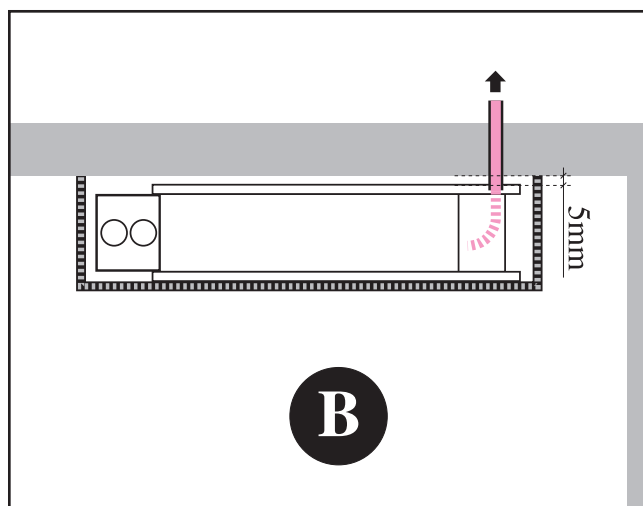
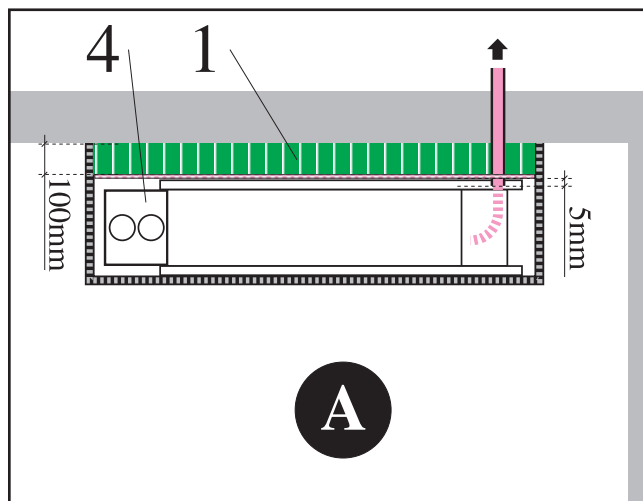

INSTALLATION

Choose the installation zone while remembering that high temperatures develop inside the partition walls (1).

⚠ Before proceeding with installation, check the data on the plate of the appliance correspond to the type and pressure of the gas supplied. Installation and connection of the gas must be carried out by qualified staff, in strict compliance with the standards in force on the matter. Ensure the gas arrival duct has a suitable capacity and that the shut-off tap is near the fireplace and easily accessible.

⚠ Check the space around the explosion-proof door (2) is always free of obstacles and cannot obstruct its opening.

Sequence:

- Anchor the appliance on the masonry walls, use anchorage brackets (4) and plugs (both not on manufacturer's pricelist) adequate for the type of wall available. Fasten the brackets on the top part of the appliance using the holes planned (5), naturally always comply with safety distances.

⚠ For corner installation, ensure an adequate anchorage system (not on manufacturer's pricelist).

- Install the tubing and terminals for extraction and fume discharge, then check correct sealing of all the connections.

⚠ Before walling in the tubing, insulate the fume discharge tubing, with resistant materials for high temperatures (e.g. HT/- Armaflex).

- Connect the gas (Methane or LPG) in compliance with the dimensions of the tubes, eliminate any burrs and internal impurities.

⚠ Before starting the appliance, in compliance with standards

UNI7129/7131/10738, carefully check:

- the appliance sealing;
- operation and sealing of the discharge duct;
- regulation tap operation
- main burner operation;
- gas pressure test, with micro-gauge to insert in attachments 1 and 2 (inbound).

- Appliance insulation:

- a) the one side insert has rear protection;
- b) the two side insert does not require insulation.
- c) the two side model with cover casing (standard) does not require any insulation;

⊘ Do not directly insulate the rear of the appliance. leave an air gap to avoid overheating or breakages (see Chap. Safety distances).

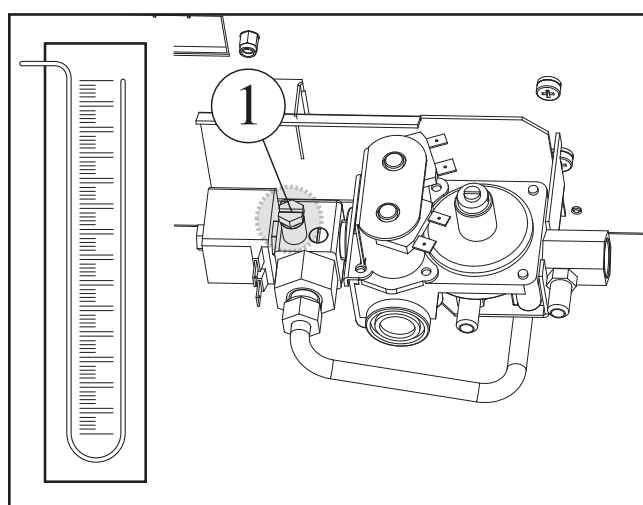
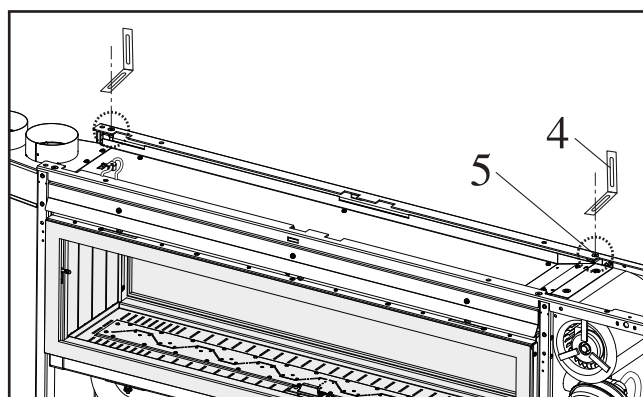
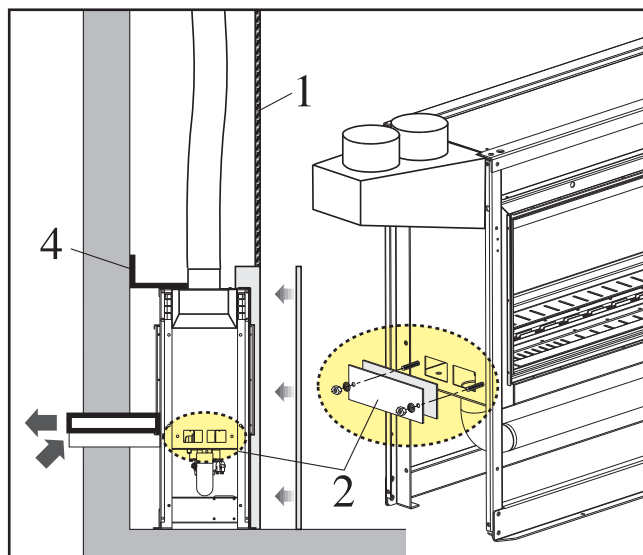

WOOD WALLS PROTECTION KIT

This unit is suitable for walls with a thickness between 100 and 500 mm.

- Having chosen the position of the appliance according to the instructions in the installation manual, make a through-hole in the wall with a diameter (A).

Carry out this operation with utmost caution to install the fume discharge unit in a straight position flush to the wall.

- Insert the frame unit in silumin in the wall, carrying out the following operations:

1) Measure the thickness of the wall excluding the stainless steel plate (1 and 3).

Fasten the internal plate (1) so that the pins engage inside the tube.

2) Assemble the outer part (3) in AISI 304 stainless steel outside the wall using the 4 screws contained in the packaging; if the external wall is in stone, choose screws and plugs suitable for this material.

Apply a waterproof mix (e.g. Secomasic or Silastic) between the plate and the wall to prevent internal rainwater penetration.

Mod.	Ø	A	L	
80 130	54	128	500	mm

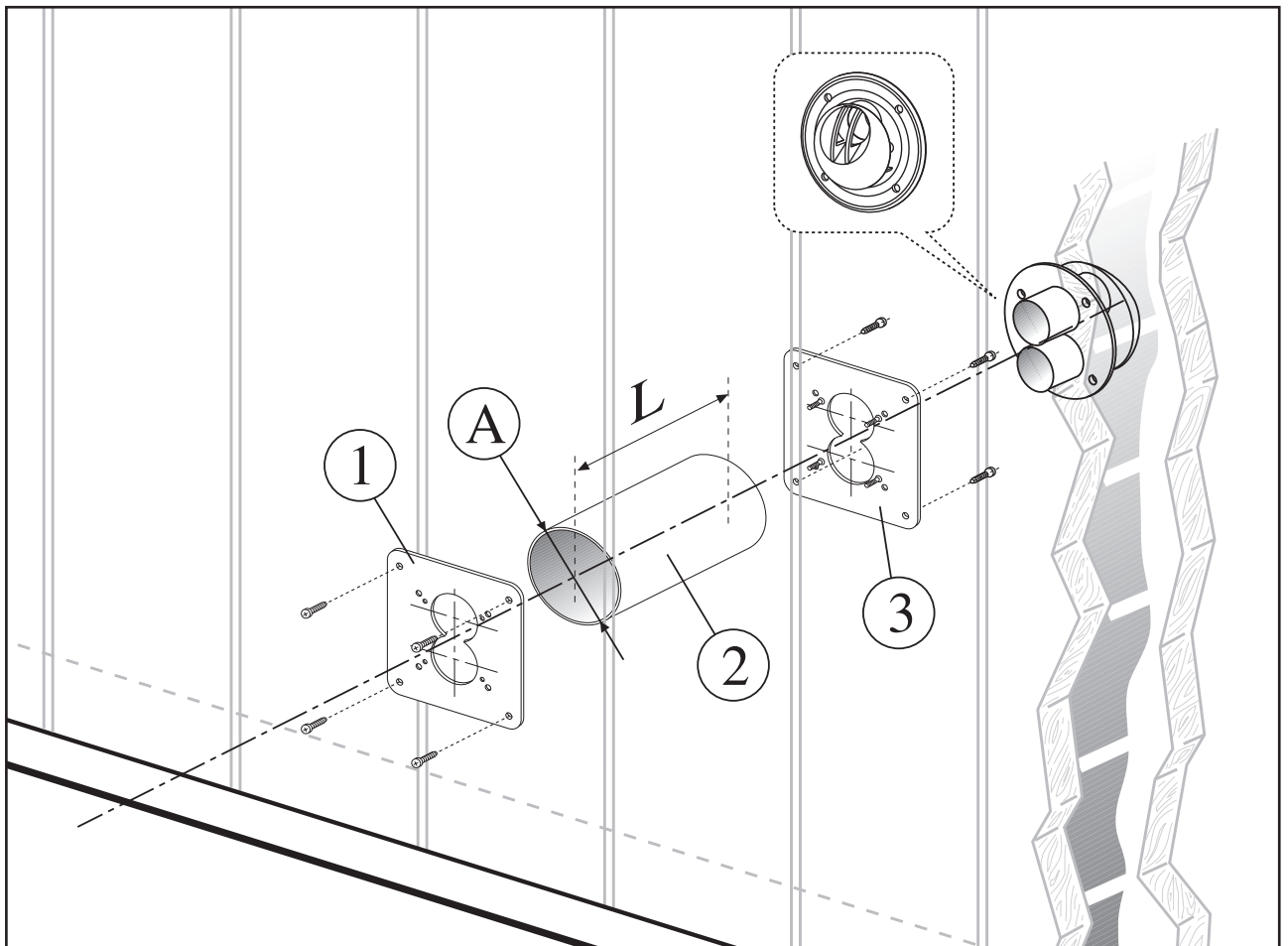

ELECTRICAL CONNECTIONS

Installation of the appliance must be carried out by an authorised company pursuant to Law 5 March 1990 no. 46 which at the end of the works issues the owner with a Declaration of Conformity for state-of-the-art installation, according to national and any local legislation in force in compliance with Art. 17 Law 46/90, and the instructions provided by the manufacturer in the installer's manual with the product.

All our products exit the factory completely cabled and with a socket for connection to the electrical power mains. You only have to implement a power cable type HAR H05 RRF with a MIN section of 1 mm² using, for the connection to the appliance, the mobile socket provided creating the GROUND cable 2 cm longer than the PHASE and NEUTRAL conductors. Connect the other end of the cable to a monopolar socket or switch, in compliance with the CEI standards connected to an efficient GROUND system.

 It is compulsory to implement a connection to an efficient GROUND system.

The manufacturer of the appliance cannot be held responsible for any damage caused by no ground on the system.

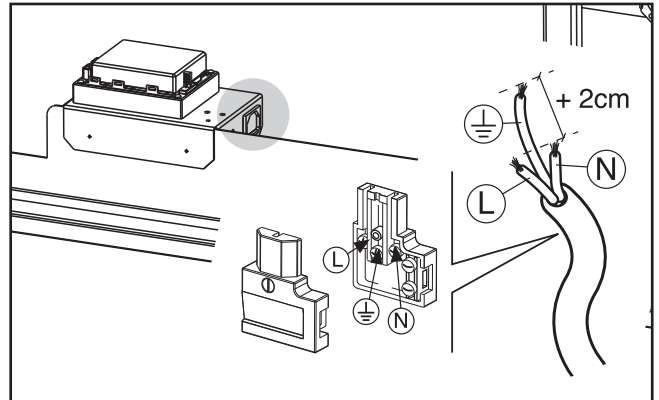

For interventions of an electrical nature, refer to the diagram included in this manual.

Install a disconnection device from the electrical mains upstream of the power cable (monopolar switch or plug) to guarantee opening of the contacts of at least 3 mm.

 Unsheath the GROUND conductor by at least 2 cm longer than the other two cables.

 Use is forbidden of gas and/or water tubes to ground the appliance.

GAS LINE CONNECTION

Ensure the APPLIANCE is prepared for the type of gas to use, checking the technical plate.

Connect the APPLIANCE to the gas supply line using the fitting and the tap supplied with the appliance and with the rigid tubing and with the fittings in compliance with standards in force. The attachment installed on the appliance is 3/8" M according to standard UNI ISO 7/1.

Having completed connection to the gas line, carry out seal testing of the system according to the provisions of installation standards in force.

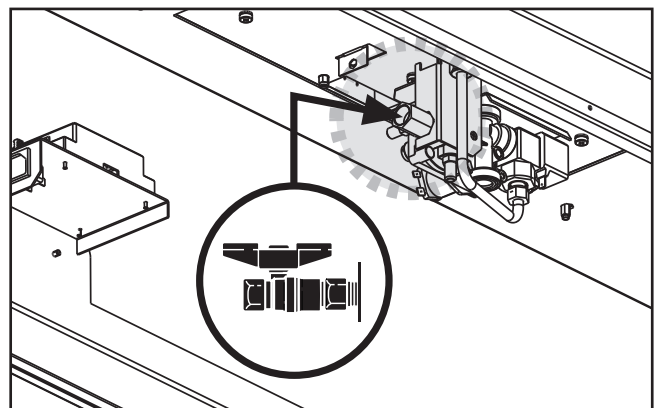
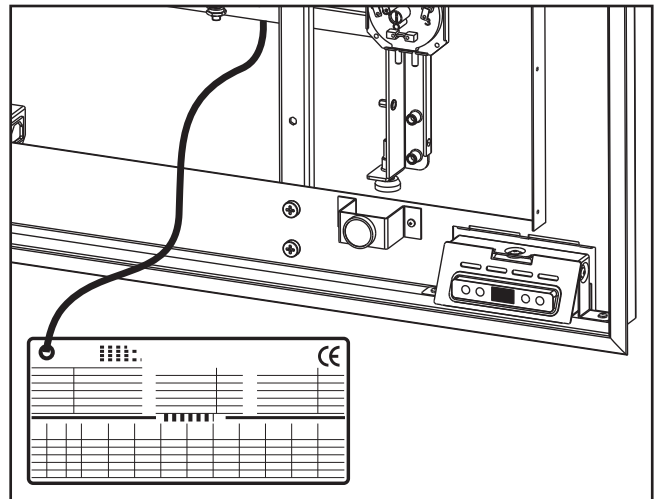



PRELIMINARY CHECKS BEFORE START-UP

The APPLIANCE is supplied prepared for operation with methane gas (G20) and pre-adjusted in the factory. Note: on request, the appliances can be provided prepared for operation with LPG.

Before switch-on and functionality testing of the APPLIANCE, check:

- the appliance is prepared for the type of gas used.
- the connection was installed correctly to the gas line and the tap is open.
- the connection to the electrical power supply was installed correctly.

 Respect the phase-neutral connection and it is compulsory to install an efficient ground connection.

 During first start-up, emissions of vapours or annoying odours, which are not hazardous, may occur. To avoid such problems, you are advised to ventilate the premises.

ATTENTION! BEFORE SWITCHING ON THE APPLIANCE, READ ALL THE INSTRUCTIONS AND WARNINGS CAREFULLY CONTAINED IN THIS MANUAL.

During first switch-on of the appliance, unpleasant odours and vapours may be emitted. This is completely normal. You are advised to adequately ventilate the premises.

On switch-on, leave the appliance to work for approximately ten minutes and at maximum power, to allow its adequate heating.

FIRST START-UP

After preparation operations on first start-up, to operate the appliance you must:

- Check the fuel tap is open.
- Insert the mobile socket in the plug installed on the appliance.
- Turn the main switch of the electrical system, if present, "on" or insert the power cable plug in the socket on the wall.
- Switch on the appliance by pressing the ON/OFF key (see User section).
- Adjust the ambient thermostat to a high value to reduce to a minimum the time for full operation.

The APPLIANCE will execute start-up and remain running until the adjusted ambient temperature is reached.

If there are start-up or operational faults, the APPLIANCE will execute a "BLOCK STOP" and the unlock signal will switch on, on the display. To restore the start-up conditions, press the unlock button and wait for the entire start-up phase to execute again until the operating signal switches on

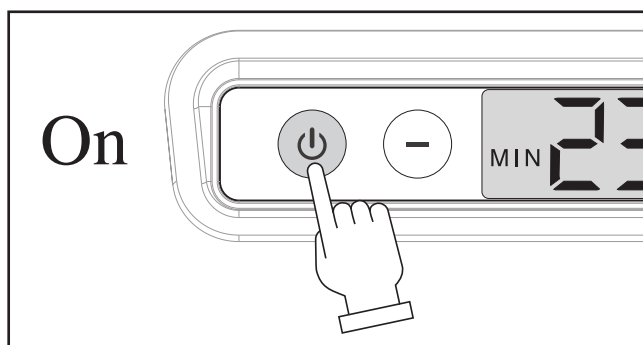
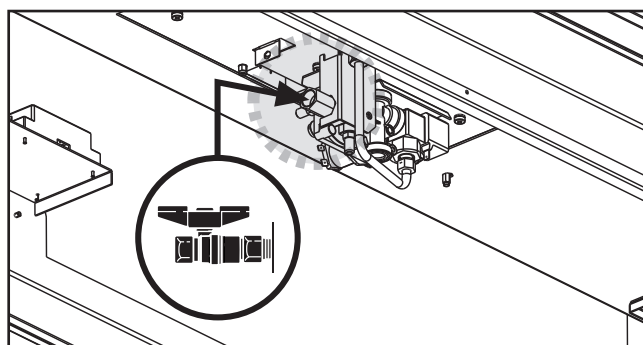
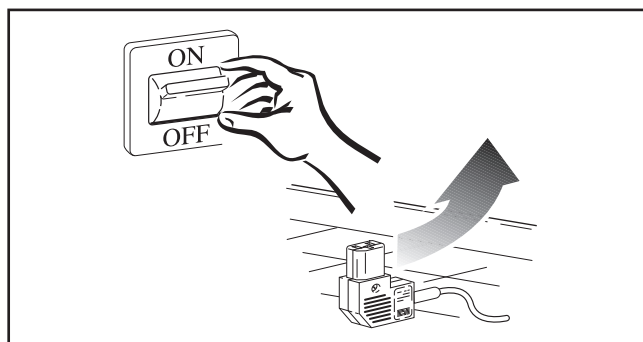

CONTROL UNIT MALFUNCTIONS

If malfunctions should occur of the control unit, we have various RESET modes:

a - press the On/Off button as in the figure.

b - disconnect and reconnect the current socket of the plug on the appliance and position the main switch off and then reposition on.

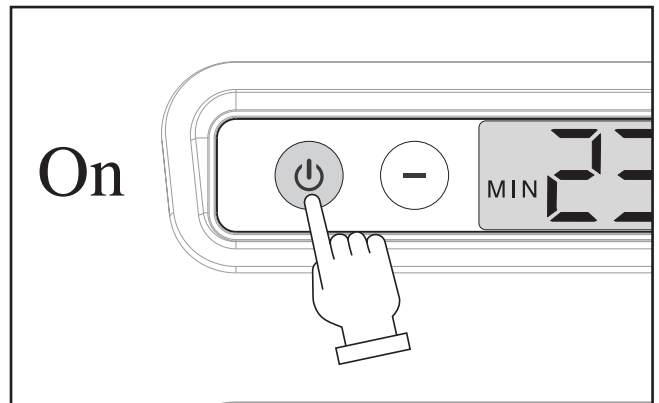

CHECKS DURING AND AFTER START-UP

On start-up, the following must be carried out:

- The gas pressure values on pressure intake (1) are as follows:

MODEL	G20 <i>nom. / verl.</i>	G31 <i>nom. / verl.</i>	
80	12,0 / 7,0	36,8 / 20,0	mbar
130	12,0 / 7,3	36,8 / 20,0	mbar

- the appliance executes stoppage and subsequent restart:

- activating the main switch of the control panel
- intervening on the ambient thermostat or the timer

- The fan starts when the consent thermostat intervenes.

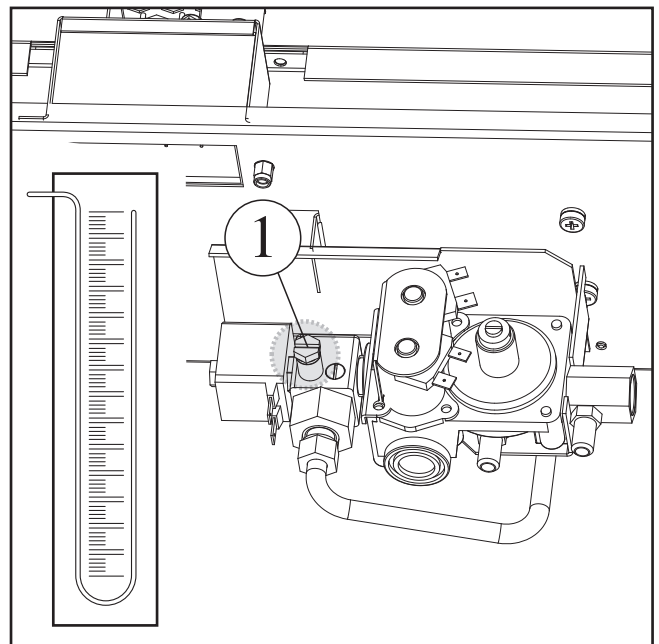

ASSEMBLY OF THE DIGITAL REMOTE CONTROL

For correct installation of the remote command in the position desired by the user, follow the instructions:

- Choose the remote position:
- far from the appliance;
- Install the remote.

⚠ For correct operation, install the remote at a MAX distance of 6 metres.

- Remote far from appliance

This solution was designed to detect the optimal comfort ambient temperature. In fact, in this position the remote "senses" a temperature at man's height.

⚠ For correct operation, install the remote at a height off the ground between MIN 1m and MAX 1.5m.

Installation:

- choose the position;
- open the remote, insert the batteries and test;
- display operation
- action range (see User section)

Check the action range:

A) If the LED flashes 4 times per second, receipt is correct.

B) If the LED flashes slowly, you are at the limit of the action range.

C) If the LED does not flash, you are outside the action range.

- mark on the wall the position of the fastening holes and drill;
- insert the plugs and screws on the chosen wall;
- fasten the rear part of the remote on the wall;
- assemble the front part with the display.

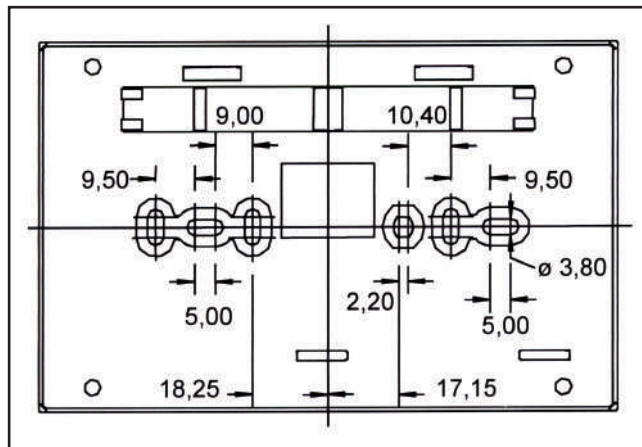
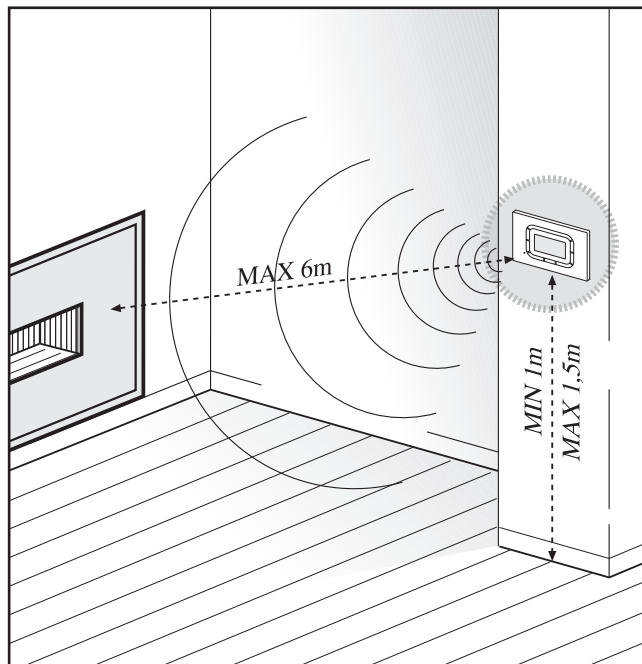

ADJUSTMENTS

The APPLIANCE is supplied prepared for operation with methane gas (G20) according to the technical plate and was already adjusted in the factory by the manufacturer.

The adjustments can be carried out exclusively by the manufacturer's Technical Support Service.

- Adjustments with Methane gas G20 (20mbar); nominal and minimum pressure.

- Open the gas tap, insert the electrical power socket in the appliance plug and start the "APPLIANCE" in "winter" at maximum power.

Supply pressure testing

- loosen the screw of the pressure intake (1), connect the gauge and check the mains pressure value is between 17 and 25 mbar (as indicated in the Table), close the intake after removing the gauge tube.

- loosen the pressure intake screw (2), connect the gauge and check the nominal and minimum pressure values comply with the values specified in the Table.

Nominal pressure adjustment

- select and enter the "nominal power" setting via the remote control.

If necessary, use the pressure regulator (5) having removed the safety plug.

Turning the regulator CLOCKWISE increases the pressure, turning it ANTI-CLOCKWISE reduces the pressure.

Reduced pressure adjustment

- disconnect the electrical power supply of the appliance.

- behind the command on the display, change the position of jumper JP1 (the one nearest to the fuse), to close the bridge and force the appliance to operate at "Reduced power".

- re-connect the electrical power supply.

- use the minimum screw (4).

Turning the screw ANTI-CLOCKWISE increases the pressure, turning it CLOCKWISE reduces the pressure.

- following adjustment: disconnect the electrical power supply of the appliance before re-inserting the jumper in its original position, disconnect the gauge from the pressure intake and close the pressure reading screw.

- having terminated adjustments, seal the modulator screw and the regulator screw with a drop of varnish.

- disconnect the gauge from the pressure intake and close the screw.

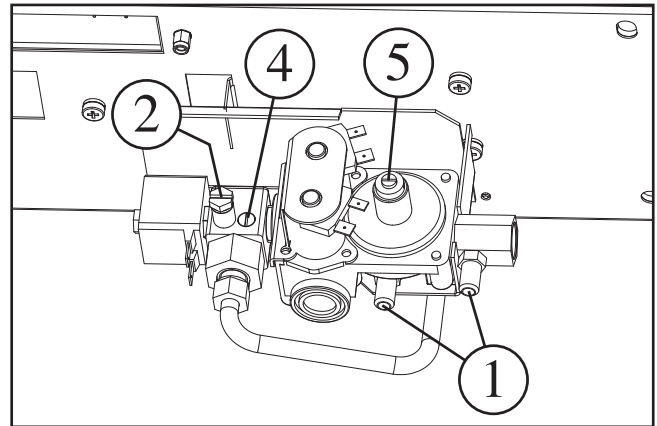

MODEL	G20 nom. / verl.	G31 nom. / verl.	
80	12,0 / 7,0	36,8 / 20,0	mbar
130	12,0 / 7,3	36,8 / 20,0	mbar

- Adjustments with LPG - Butane G30 (29 mbar) and Propane G31 (37 mbar); nominal and minimum pressure.

- Open the gas tap, insert the electrical power socket in the appliance plug and start the "APPLIANCE" in "winter" at maximum power.

Supply pressure testing

- loosen the screw of the pressure intake (1), connect the gauge and check the mains pressure value is between 29 mbar with Butane and 37 mbar with Propane (see Table).

- loosen the screw of the pressure intake (2), connect the gauge and check the pressure value complies with those indicated in the table for the type of gas used (see Table).

If the mains pressure is insufficient, use the low pressure regulator on the main distribution or on that assembled outbound of the canister.

Check the vaporisation capacity of the LPG system is sufficient.

Nominal pressure adjustment

- select and enter the "nominal power" setting via the remote control.

- if necessary, use the pressure regulator (5) having removed the safety plug.

- turning the regulator CLOCKWISE increases the pressure, turning it ANTI-CLOCKWISE reduces the pressure.

In **LPG** operation (**category 3+** only), the regulator must be placed outside screwing the calibration screw of the regulator (5) clockwise at a value immediately under the maximum supply pressure. If the appliance is adjusted to pure Propane, to avoid overheating the exchanger, always check the supply only includes this type of gas and do not mix **Propane/Butane** or **Pure Butane**.

Minimum pressure adjustment

Follow the same instructions described in “Reduced pressure adjustment”.

Ambient Thermostat PROBE compensation

This function allows you to compensate the different between the temperature detected in the point in which the sensitive element is found of the ambient temperature probe and the well-being temperature you want to have in the premises (see USER section).

ROUTINE MAINTENANCE

Periodic maintenance, once a year, is essential for safety, efficient and duration of the appliance. It allows you to reduce consumption and pollutant emissions.

Remember that maintenance must be carried out by the manufacturer's Technical Support Service or by professionally qualified staff who will carry out, if necessary, cleaning of the burner and the electrodes on start-up and detection of the flame and will control the adjustments of the appliance.

Preliminary operations:

- Disconnect the electrical power supply by detaching the current socket from the plug on the machine, or positioning the main switch off.
- close the gas tap.
- wait for the APPLIANCE to cool completely.

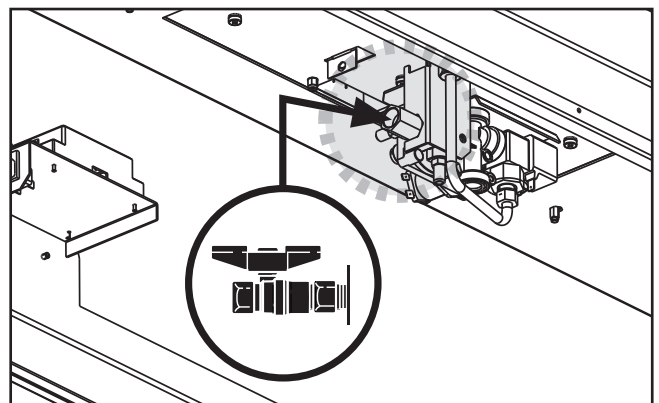
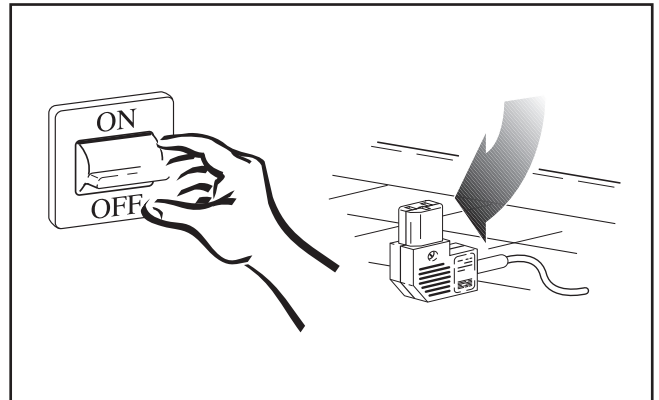

CLEANING OF THE APPLIANCE

Cleaning the outer surfaces

Clean the accessible parts, to remove any dust deposits, cobwebs and similar.

Use compressed air to blow the dust away also in difficult to access points.

To clean parts in plastic or painted material, do not use any solvents or abrasive detergents, which could compromise the treated parts. Use neutral products, available on the market. Do not grease parts in synthetic material.

Use a soft cloth to clean the casing soaked in products used to clean the home or other, with a neutral base (car shampoo, etc.).

Do not pour liquids directly on the casing or on other parts of the appliance, which could seriously damage it.

Internal cleaning

For correct dismantling and re-assembly of the casing, proceed as described in the chapter DISMANTLING AND REASSEMBLY OF THE CASING.

Pressure switch testing

Check there are no deposits or condensate inside the pressure detection tubing:

- fuel air fan/pressure switch.
- fume discharge/pressure switch.

Blowing it, disconnecting it firstly from the pressure switch and checking correct operation. On the contrary, it may be damaged.

Electrode cleaning

Follow the instructions below to dismantle and re-assemble the electrodes unit:

- unscrew the screws (3) and remove the cover (4);
- delicately clean the switch-on (1) and detection (2) electrodes using a small brush with metal bristles, pay attention not to damage the ceramic material.
- re-assemble the cover (4) with the inverse sequence to dismantling.

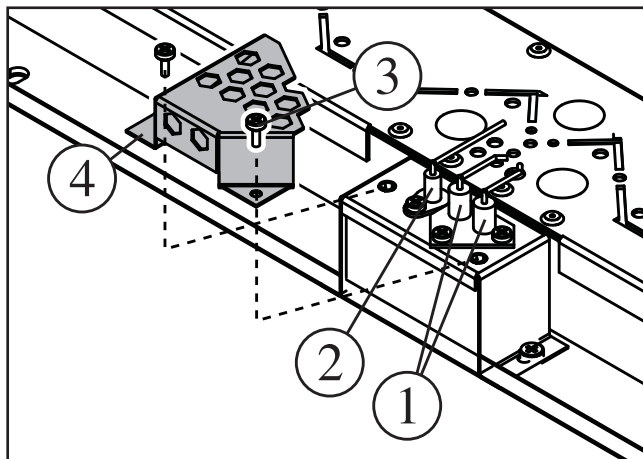

Cleaning the burner

Follow the instructions below to clean the burner unit (1):

- use compressed air, blowing near the injectors inside, thereby causing the residue and impurities left by combustion to exit, after which ensure the burners are intact.

- then, ensure the injectors are in good condition.

⚠ Do NOT use metal tools!

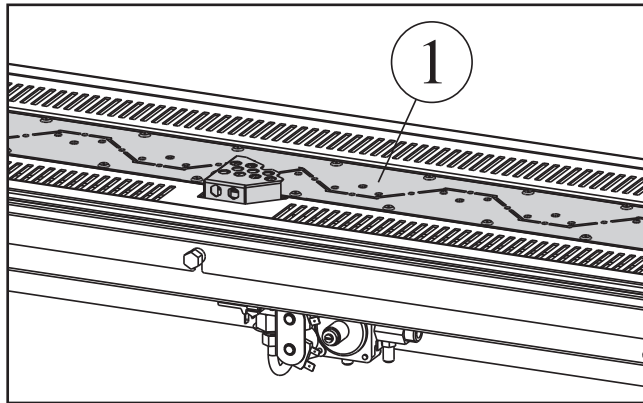

REPLACEMENT OF THE COMPONENTS

Preliminary operations:

- **Disconnect the electrical power supply by detaching the current socket from the plug on the machine, or positioning the main switch off.**
- **close the gas tap.**
- **wait for the APPLIANCE to cool completely.**

Replacement of the Flame Control board

Follow the instructions below to dismantle and re-assemble the control board (1):

- unscrew the fastening screw (2) of the board cover;
- remove the connectors from the respective plugs;
- replace the electronic board, paying attention not to incorrectly reconnect the cabling and check correct positioning of the switches.

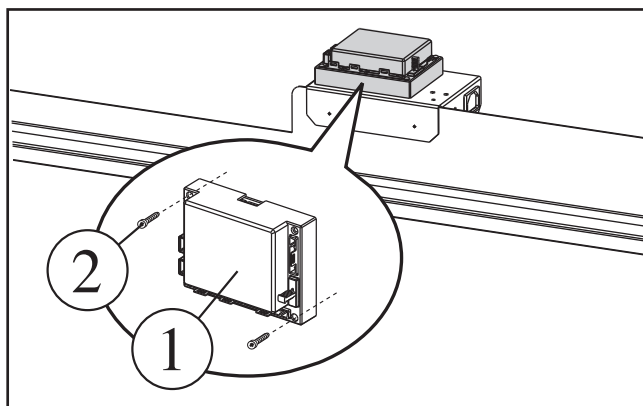

Replacement of the ambient probe (installation with remote on the appliance)

Follow the instructions below to dismantle and re-assemble the probe:

- disconnect the connector of the probe cable (1) from the control unit (2);
- remove the damaged probe;
- replace with an original component, assembling with the inverse sequence to dismantling.

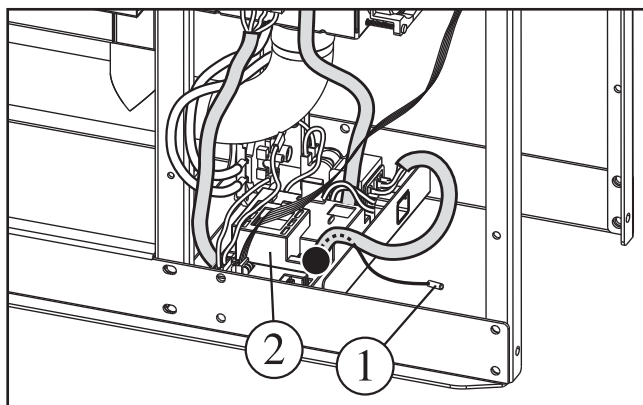

Replacement of the convector fan

Follow the instructions below to dismantle and re-assemble the fan (1):

- remove all the electrical connections on the fan.
- unscrew the screws (2) fastening the fan to the frame of the appliance and extract it.
- assemble the new fan with the inverse sequence to dismantling.

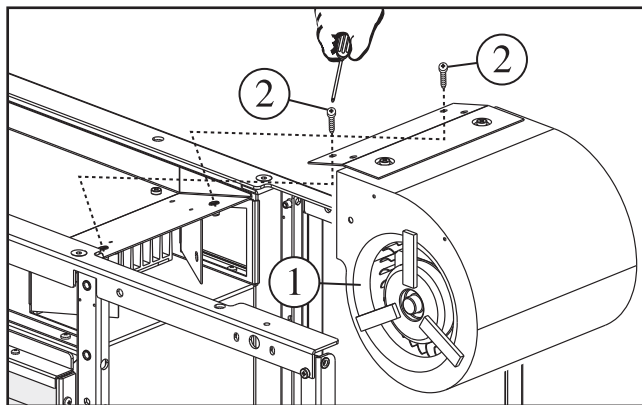

Replacement of the electrocution safety fuse

If, after an electrical system short circuits, the appliance does not switch back on, you must immediately ensure the conditions of the safety fuse; proceed as follows:

- remove the fuse holder (1);
- remove the fuse (2) checking the intactness, if brown or the internal filament is interrupted, replace it because it was burnt, with another rapid type: F1AT-250 V.

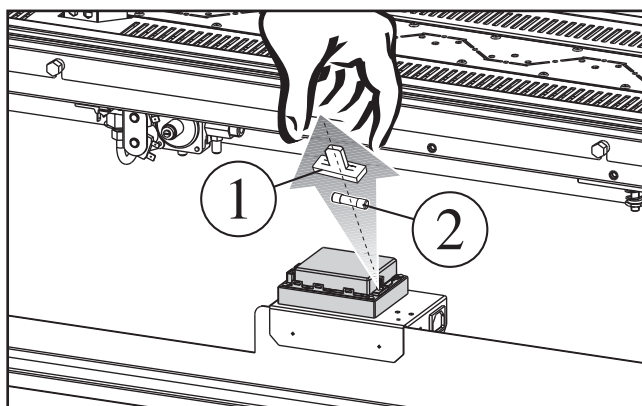

Replacement of the combustion air fan

Follow the instructions below to dismantle and re-assemble the combustion air fan (1):

- remove all the electrical connections on the fan.
- dismantle the safety thermostat (2).
- unscrew the screws (3) and delicately remove the fan.
- re-assemble the thermostat (2) of the new fan.
- assemble the new fan with the inverse sequence to dismantling.

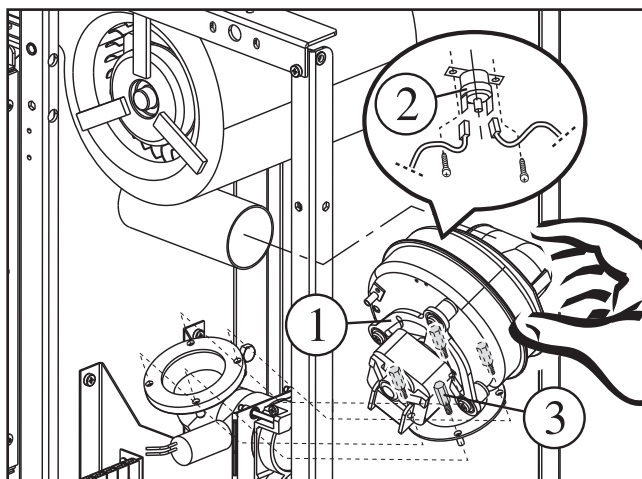

Replacement of the electrodes unit

Follow the instructions below to dismantle and re-assemble the electrodes unit:

- remove the cover grate (1).
- detach all the electrical connections.
- unscrew the screws fastening the detection electrode (2) and the switch-on electrodes unit (3).
- delicately remove them from their compartments.
- replace the damaged electrode.
- assemble the new component with the inverse sequence to dismantling.

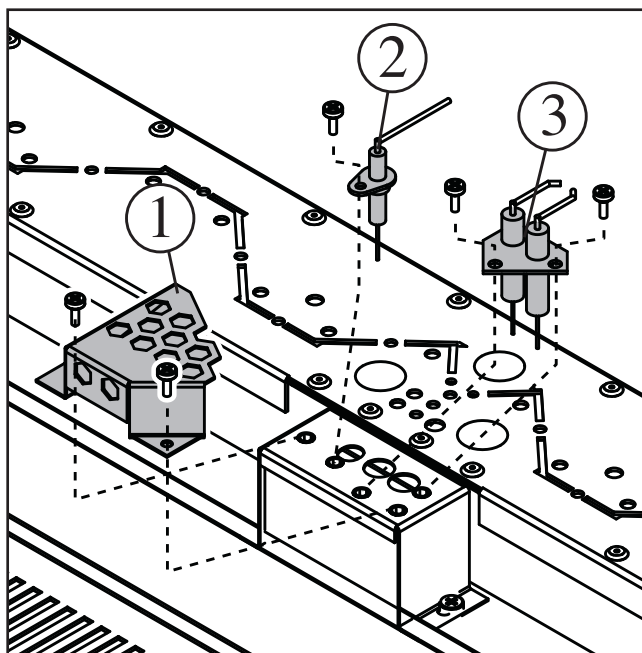

Replacement of the safety thermostat (manual resetting)

Follow the instructions below to dismantle and re-assemble the thermostat (3):

- dismantle the thermostat locking bracket (1) by unscrewing the screw (2).
- disconnect the safety thermostat electrical connectors.
- assemble the new safety thermostat with the inverse sequence to dismantling.

The safety thermostat intervenes, if the convection fan is not working properly or irregular overheating occurs and/or if the temperature of the outbound air reaches a value over 107 °C, disabling the burner, closing the gas valve and causing the appliance to block.

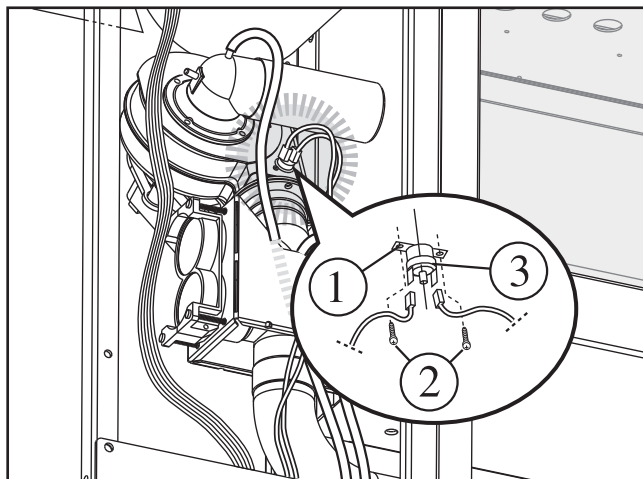

Replacement of the gas valve coils

Follow the instructions below to dismantle and re-assemble the coils:

- unscrew the two fastening screws of the bracket (4), holding the coils (1) on the valve body (2) and remove it.
- remove the faulty reel (1), carefully removing it.
- re-insert the new reel, taking care to connect the plug (3) of the contact in the specific socket.
- 4 - Re-assemble the bracket (4) to fasten the coils.

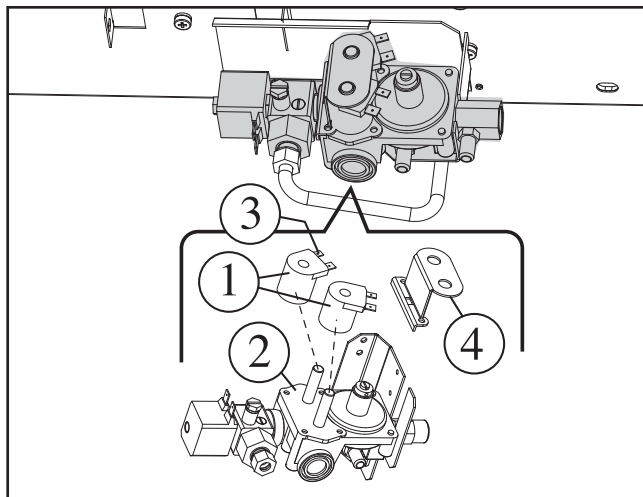

Replacement of the modular coils

Follow the instructions below to dismantle and re-assemble the coil:

- dismantle the electrical connections.
- unscrew the locking nut (1) fastening the coil (2) to the valve body (3) and remove it.
- remove the faulty reel (2), carefully removing it.

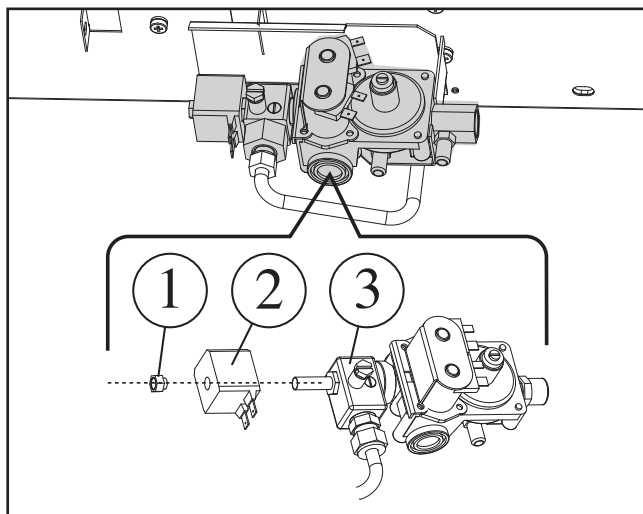

Replacement of the gas valve

Follow the instructions below to dismantle and re-assemble the valve:

- unscrew the screws fastening the valve on the support in sheet metal.
- dismantle the electrical connections.
- unscrew the screws fastening the valve on the support in sheet metal.
- loosen the locking nut blocking the tubing to the valve body.
- loosen the locking nut of the tubing connected to the electrodes unit.
- extract the faulty valve and dismantle all the gas fittings (1) connected to it.
- assemble the new valve with the inverse sequence to dismantling.

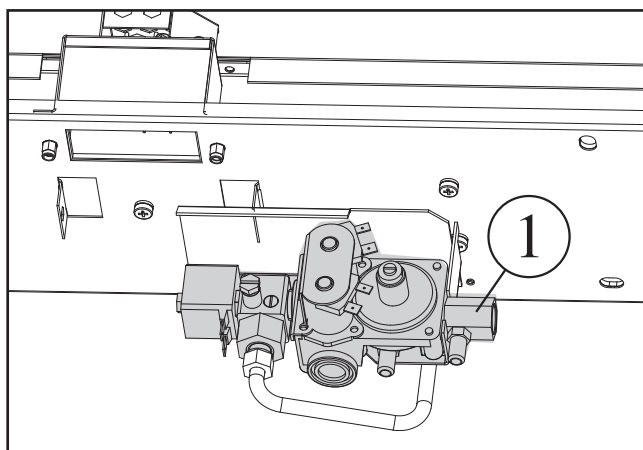

Replacement of pressure switch 1 (standard)

Follow the instructions below to dismantle and re-assemble the pressure switch (1):

- remove the pressure switch (1) from the support (2) by unscrewing the fastening screws.
- disconnect the tubes (3 and 4) and the electrical connections from the faulty pressure switch.
- assemble the new pressure switch.
- re-insert the silicone tubing and the electrical connectors, paying utmost attention to not invert them, which could cause poor operation of the appliance; if in doubt, use the wiring diagram.

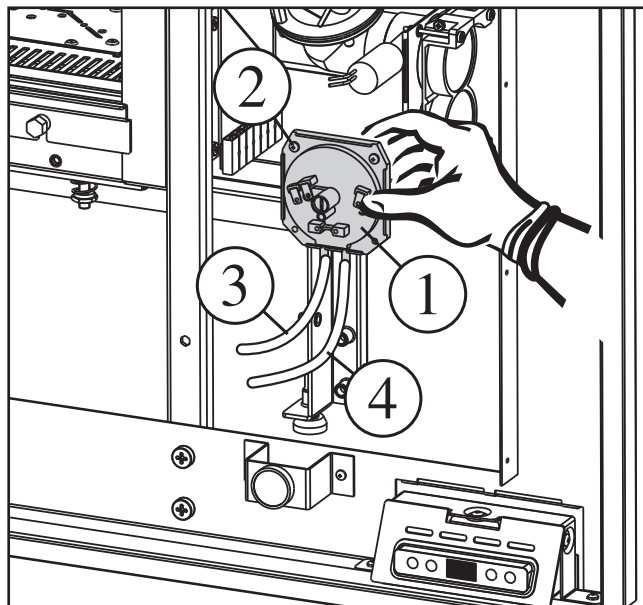

Replacement of pressure switch 2 (optional KIT)

Pressure switch 2 (1) is a necessary accessory if the appliance is installed with separate and independent tubing with two separate terminals.

Assemble and replace the pressure switch 2 with the same procedure described for pressure switch 1.

⚠ Insert the silicone tubes and the electrical connectors paying utmost attention not to invert them, which could compromise good operation of the appliance: if in doubt, use the wiring diagram.

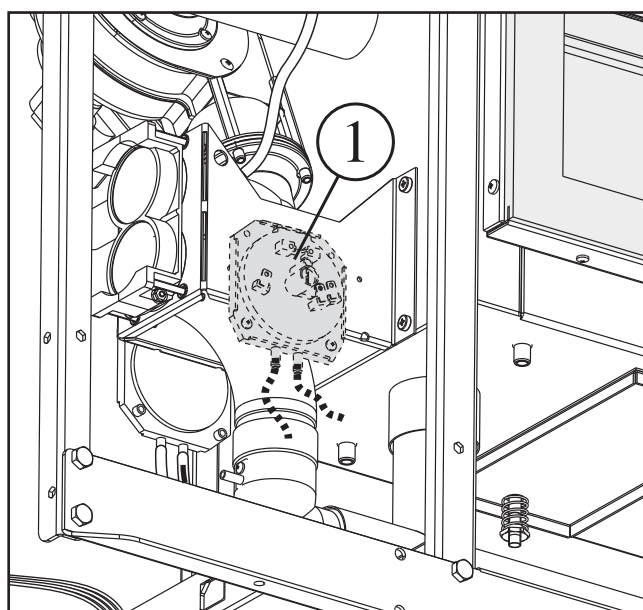

Replacement of the capacitor

Follow the instructions below to dismantle and re-assemble the tangential fan capacitor:

- detach the electrical connections.
- unscrew the capacitor (1) from the support.
- assemble the new component with the inverse sequence to dismantling.

⚠ In the event of replacement or addition of any component, only use Original Accessories and Spare Parts provided with a certificate by the manufacturer.

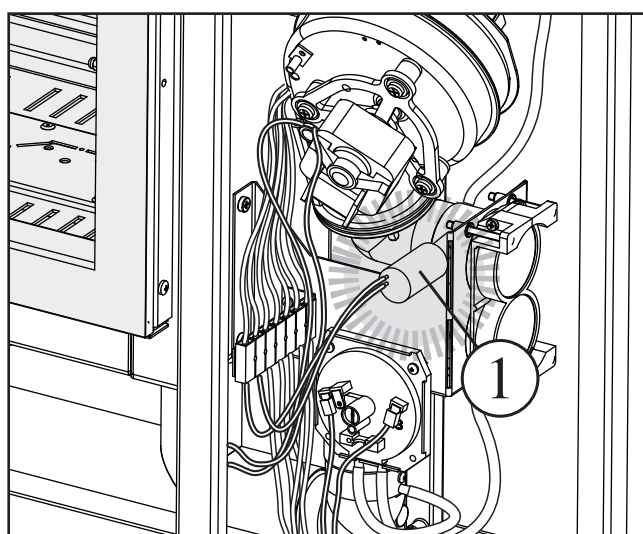

ARRANGEMENT OF THE CERAMIC LOGS WITH EMBERS, RIVER PEBBLES AND SMALL CERAMIC WOOD PIECES

The appliance can be supplied with:

- **KIT A:** ceramic logs plus a bag of embers
- **KIT B:** a pack of river pebbles

! Exclusively use the embers, the ceramic log and river pebbles supplied with the appliance, not adding others and complying with the arrangement indicated by the manufacturer.

! You are advised to always use original parts and spare parts provided by the manufacturer, installation should be carried out by staff authorised by the manufacturer of the qualified technician.

Installation

- Open the door or glass front to access the fireplace;
- Distribute the embers or stones, taking care not to penetrate inside the pilot protection, to avoid damaging the pilot or the thermocouple;
- Position the logs or stones according to the order illustrated in the assembly manual for the wood or stones;

! The handling and positioning operations of the embers and logs in the fireplace must not be carried out with work clothing with long sleeves and long trousers using:

- a protective mask, to avoid inhaling ceramic fibre particles.
- work gloves, to avoid contact with bare hands.
- work goggles with side protection, to avoid any ceramic fibre particles in the eyes.

! Position the embers, the logs or the stones, avoiding contact with the walls around the fireplace.

Carefully and delicately position the embers and all the logs, they are very fragile components. If one or more logs are broken or chipped, do not proceed with their installation, but replace them immediately.

- Perfectly close the fireplace, paying particular attention to the correct positioning of the sealing gaskets;
- Switch on the appliance to test its "behaviour" and wait for the flame.

! **ATTENTION! BEFORE SWITCHING ON THE APPLIANCE, READ ALL THE INSTRUCTIONS AND WARNINGS CAREFULLY CONTAINED IN THIS MANUAL.**

! First start-up can be difficult due to the possible presence of air in the gas tubing. In the event of brief switch-on and switch-off of the appliance, wait at least 5 minutes before repeating the switch-on operation.

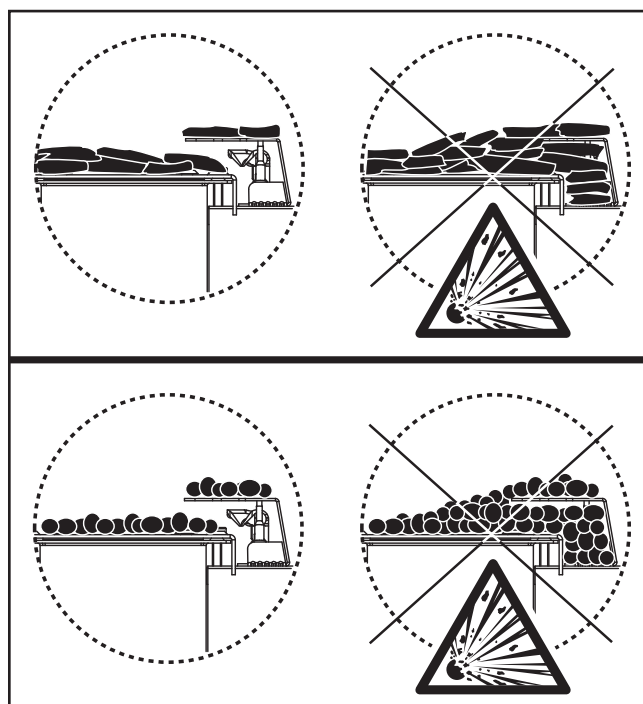

! During first start-up of the appliance, unpleasant odours or vapours can be released, which is completely normal, you are advised to adequately ventilate the premises.

! On switch-on, leave the appliance to work for approximately ten minutes and at maximum power, to allow its adequate heating.

! If you want to use the appliance for short periods of time, you are advised to switch it off, but leave its pilot flame on. This measure avoids condensate formation in the tubing which reach the fireplace and in the long term could cause corrosion of the fireplace.

Glass opening for one side and tunnel models

Removal and subsequent re-insertion of the glass must be carried out by qualified staff to guarantee the correct airtight sealing of the chamber.

- tilt and remove the side sheet metal (1);
- lift and remove the side sheet positioned at the bottom (2);

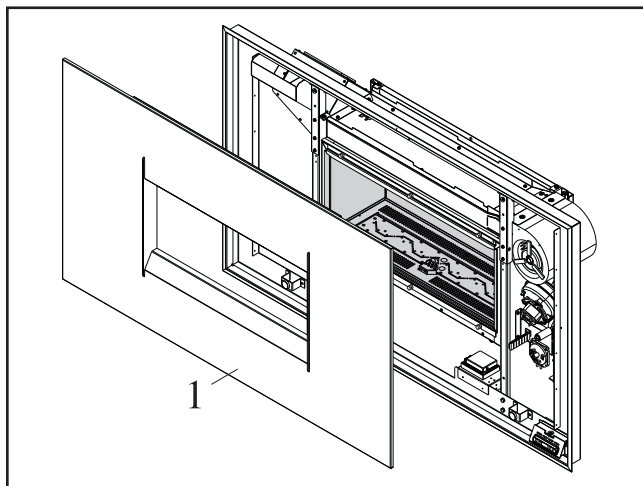

- clean and position on the glass the suction cups (3) supplied with the appliance;
- loosen, without completely unscrewing the bottom locking columns (4);
- loosen, without completely unscrewing the top locking columns (5);

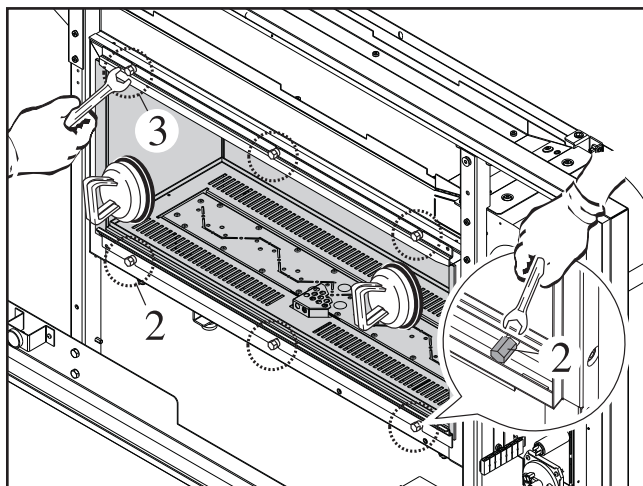

- remove the bracket (4) locking the upper part of the glass;

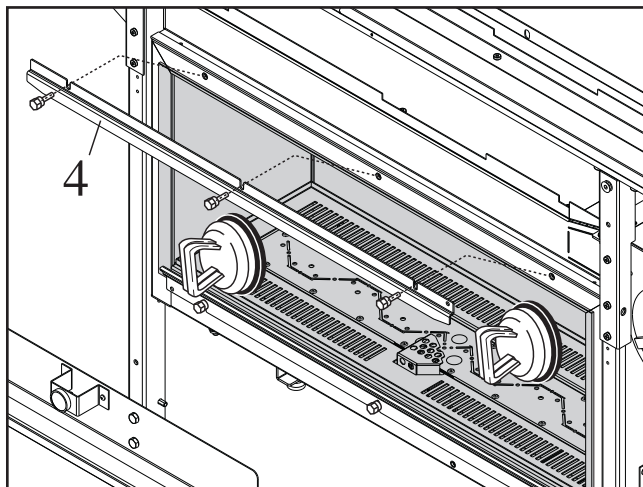

- lift the glass, release the lower part of the locking bracket (5), and then carefully remove it downwards.

⚠ Before re-assembling everything, check the intactness and correct adhesion of the gaskets on the glass to avoid possible leakage of combustion fumes.

⚠ Re-assemble the glass, paying utmost attention to its positioning compared to the fire-place. The glass must be perfectly centred to avoid possible leakage of combustion fumes.

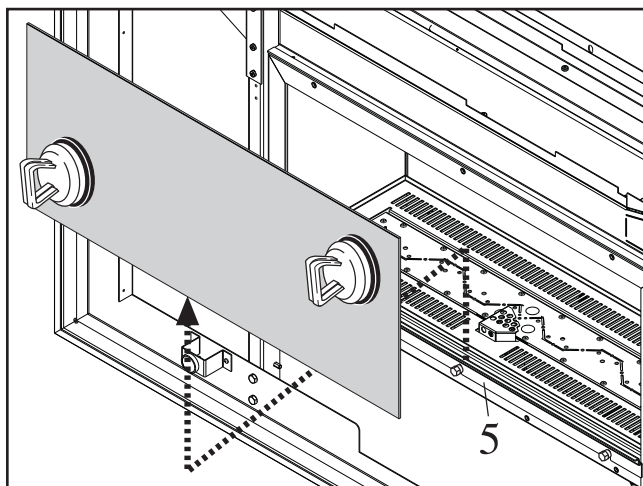

MAINTENANCE

⚠ CLEAN THE APPLIANCE ONLY WHEN OFF AND COMPLETELY COOLED.

⚠ ANY TYPE OF INTERVENTION ON THE APPLIANCE MUST ONLY BE CARRIED OUT BY A QUALIFIED TECHNICIAN AND AT LEAST ANNUALLY.

CLEANING THE COVERING:

Clean with a soft, dry cloth before using any detergent (even if delicate). After this initial operation, you are advised to use degreasing and non-aggressive detergent.

• **Varnished metal**, use a cloth dampened with water

⚠ Do not clean the painted metal parts with alcohol, diluents, benzene, acetone or other degreasing or abrasive substances. If used, the manufacturer cannot be held in any way liable for any damage caused: variations in colour, scratches, etc.

• **Glass**, use a soft cloth dampened with water or with products suitable for cleaning polished, mirrored and glass surfaces.

Cleaning the fireplace

• Check all the gaskets of the door (glass included) and replace them, if necessary.

• **GLASS**

⚠ To clean the glass, use a soft and dry cloth.

A) Delicately pass the cloth on the glass to remove a first layer of dirt.

B) Spray degreasing detergent with a neutral base (car shampoo, etc.) on the glass and dry with a soft cloth.

• **Ceramic LOGS**

⚠ Remove each element from the appliance, paying attention not to damage it, if broken replace it immediately.

Clean each log with a delicate spray of compressed air, during cleaning operations to avoid too close contact with the part to avoid any damage or breakage.

⚠ Do not wash the logs with water or other liquids to avoid compromising their intactness and exterior appearance.

• **STONES**

⚠ Remove each element from the appliance, paying attention not to damage it, if broken replace it immediately.

Burner check and gas leak testing

- Check cleaning and intactness of the burner.
- Check the gas output safety system, if necessary work on the burner. A technician should also check the inbound pressure of the burner.
- Check for any gas leaks on the system.
- Check switch-on.

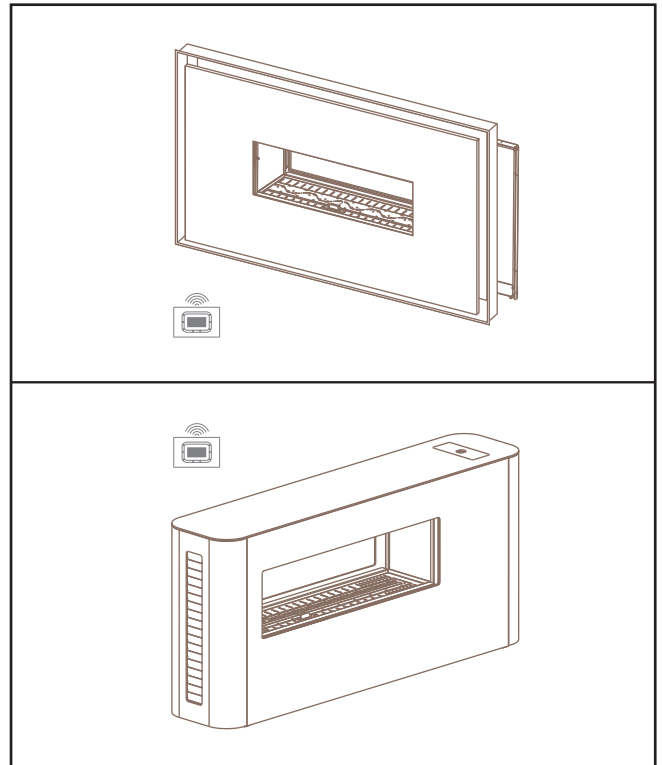

⚠ Only use the manufacturer's original spare parts, using non-original spare parts could cause the immediate invalidity of the warranty. They can also be dangerous or damage the appliance.

⚠ The appliance must be intended for the use planned by the manufacturer or for which it was expressly manufactured.

All contractual or non-contractual liability is excluded on the manufacturer's side for damage caused to people, animals or property caused by wrong installation, adjustment, maintenance or improper use of the appliance.

⚠ Spare parts and/or technical interventions require the exact identification of the appliance model on which they are intended.

Tampering with, removal of or missing technical plate or anything else does not allowing certain identification of the product making any subsequent installation or maintenance operations difficult.

DISMANTLING AND RE-ASSEMBLY OF THE CASING

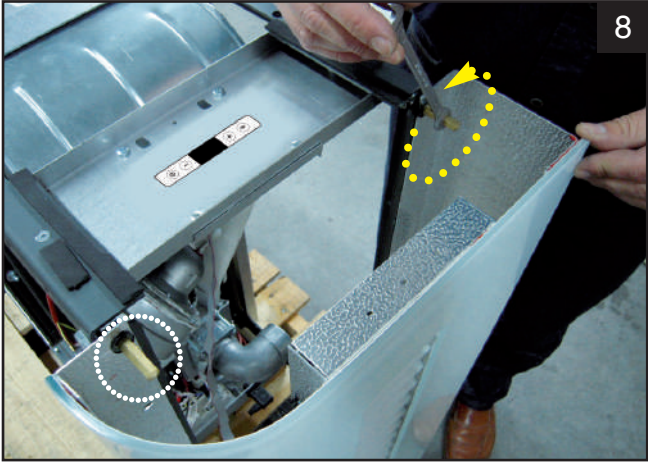
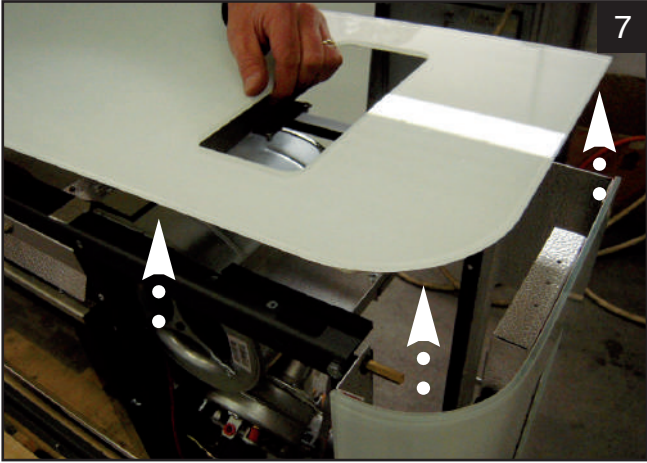
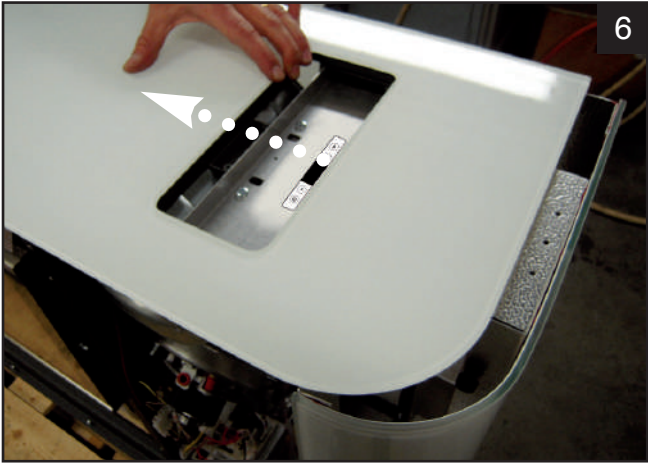
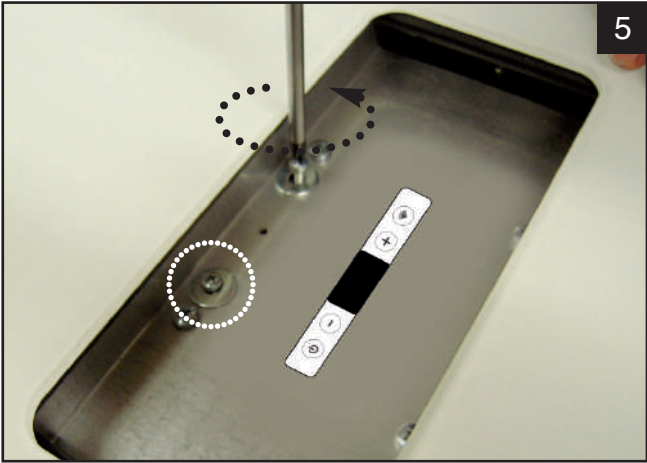
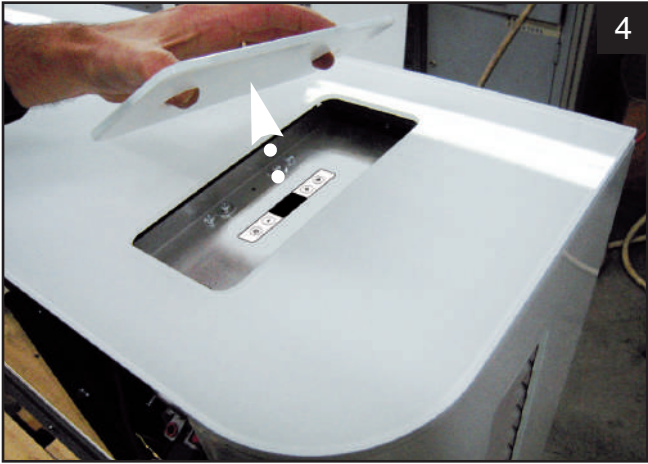
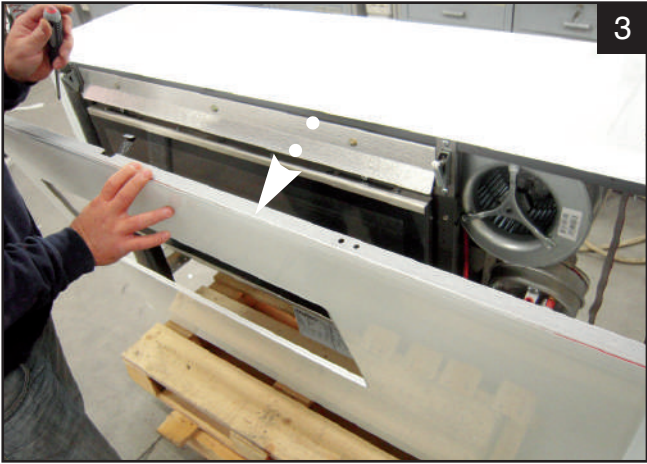
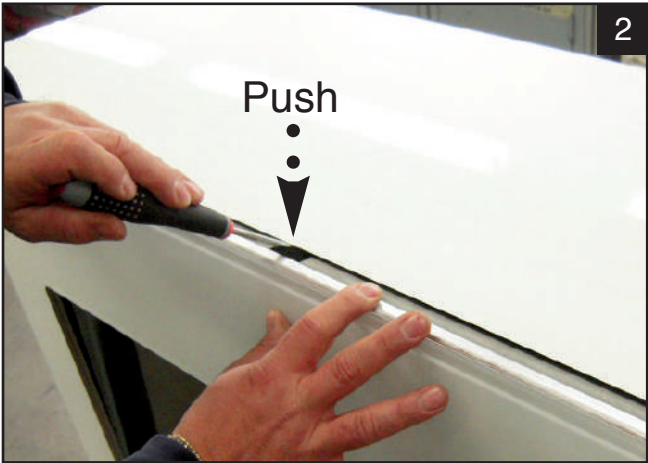

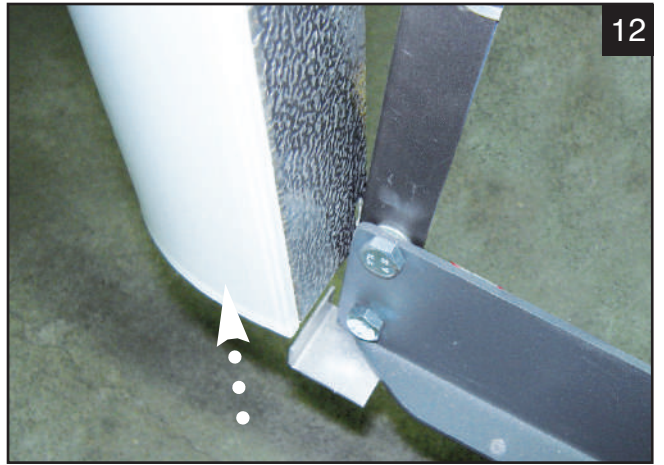
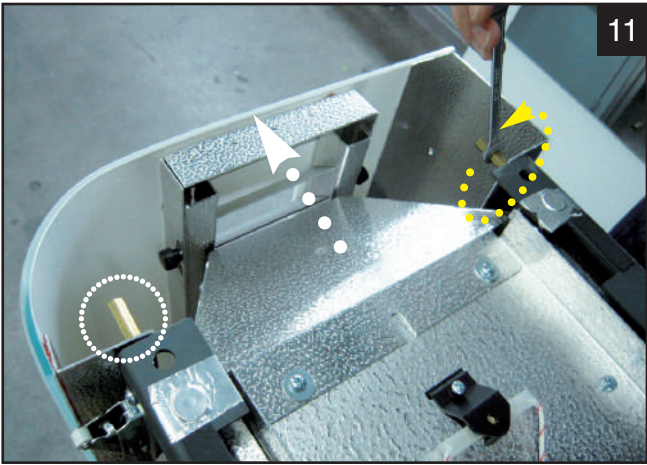
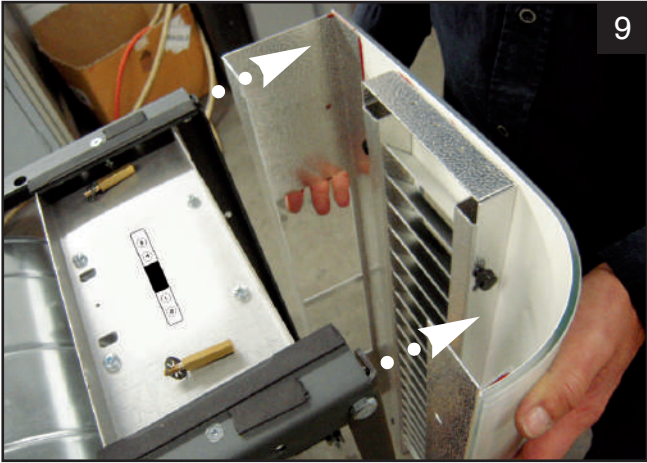

CASING ADJUSTMENT

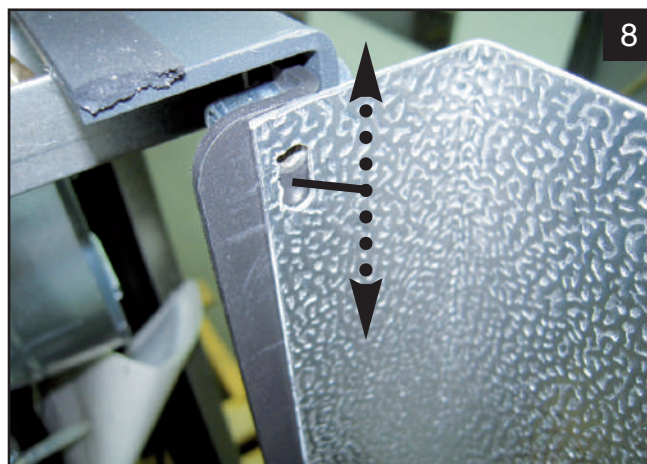
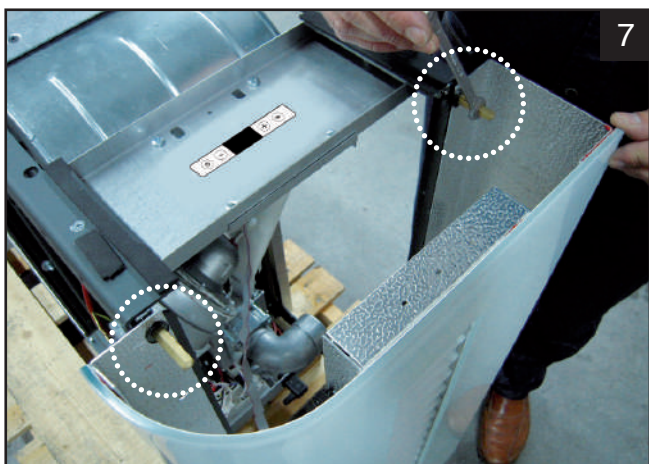
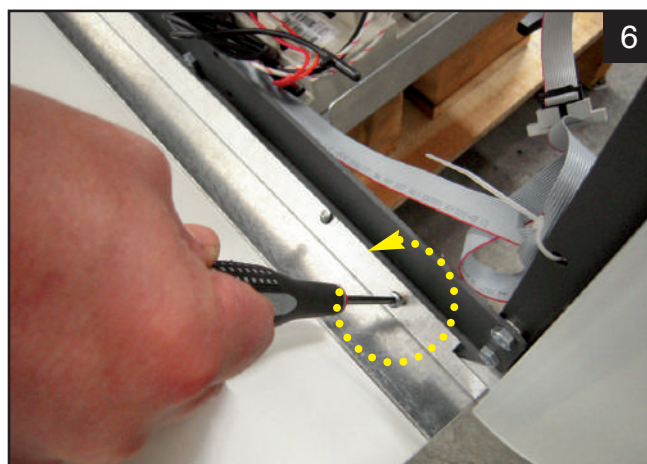
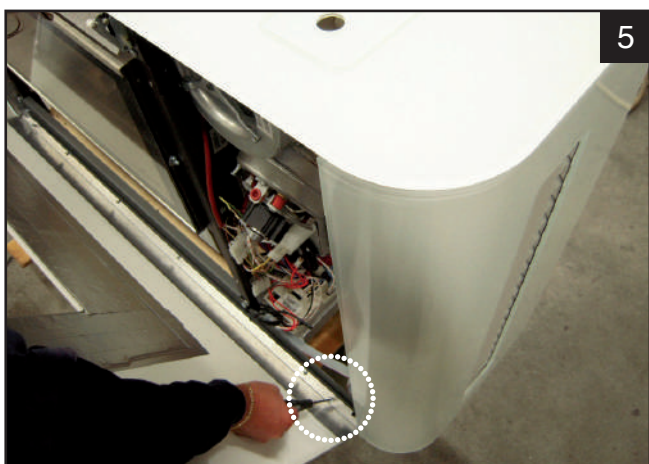
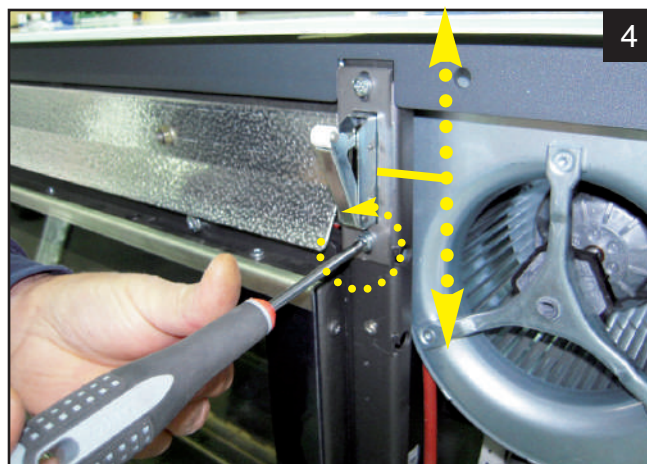
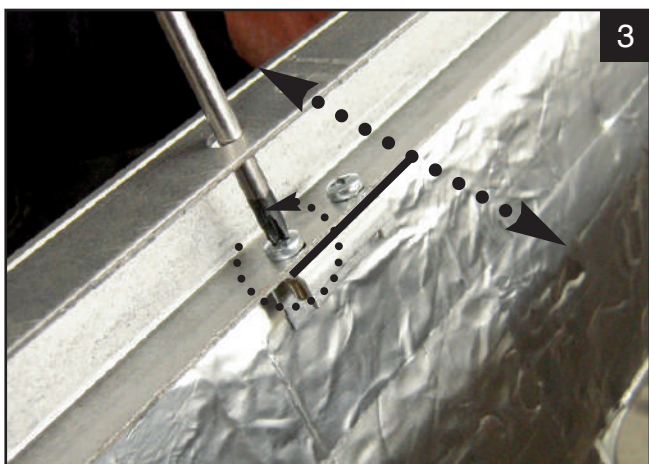
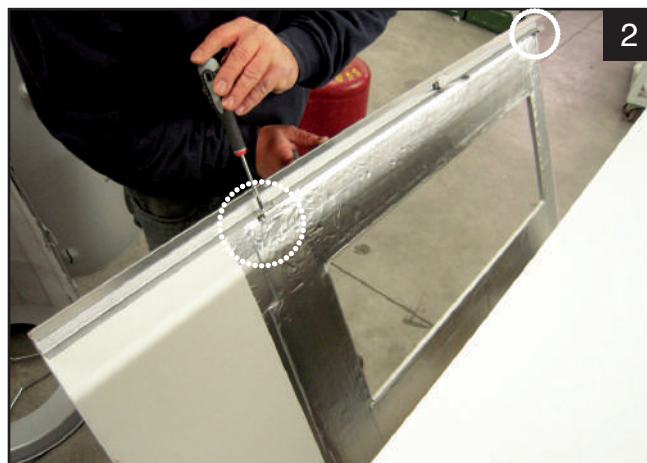
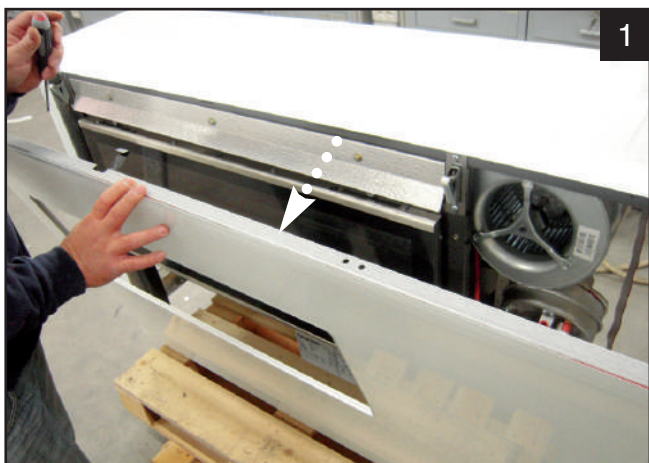

FAULTS AND SOLUTIONS

The main burner is not working

- Check correct pressure and gas supply.
- Switch on the appliance to the maximum, close all the other gas utilities and read the meter.

⚠ Check the correct combustion of the burner: uniform flame over the entire surface of the burner.

The appliance won't start

- Check On/Off switch is working.
- Check manual commands are working.
- Check the control unit is set for this type of appliance.
- Check the Wireless command is set for this type of appliance.

FAULT	CAUSE	SOLUTION	
The appliance won't start (appliance not enabled)	Electrical power supply disconnected	Check power supply	
	Irregular gas pressure	Calibrate to right pressure value	
	Thermostat does not activate	Adjust thermostat	
	No pressure switch consent	Check / Replace - non-conforming tubing (diameters, length, number of curves, obstructions, assembly) - pressure switch (operation/connections) - small pipes (intact/clean) - centrifugal ventilation (connections/operation)	
	Fuse burnt	Replace	
	Control board faulty	Replace	
	Ambient temperature high	Amb. thermostat on higher values.	
	Air present in gas tubing	Purge	
	The appliance won't start (appliance not working properly/blocked)	Irregular distance of start electrodes	Restore correct distance
		Dirty nozzles	Clean the nozzles
		Nozzles non-conforming with gas used	Assemble correct nozzles
Control board faulty		Replace	
Gas valve closed		Check / Replace - Safety thermostat activated (Tang. fan or thermostat faulty, gas calibration) - Faulty valve	
Wireless synchronisation not enabled		Synchronise wireless	

FAULT	CAUSE	SOLUTION
The ambient thermostat does not activate	Thermostat programming to adjust	Adjust thermostat - Increase - Decrease
	Chronothermostat or appliance unfavourable position	Change position
	Ambient BUILT-IN probe faulty	Replace wireless
No spark on start-up	Electrodes unit for start/detect faulty, ground or connected incorrectly.	Check / Replace
	Flame control board faulty	Check / Replace
Burner switches on when running	Gas pressure insufficient or irregular	Check/Adjust gas
	Extraction or discharge tubing incorrectly assembled	Check / Restore: - tubing length - appliance / tubing seal
	Extraction/unloading diaphragm not installed	Insert diaphragms
The appliance doesn't heat much	Progr. HOT in MIN position	Program on MAX position
	Gas pressure / nozzle non-conforming	Check and adjust gas / Replace
	Inadequate appliance power to premises	Replace appliance with a more powerful one
The centrifugal fan won't start	Control board faulty	Replace
	Motor faulty	Replace
	Pressure switch faulty	Replace
The tangential fan won't start	Control board faulty	Replace
	Motor faulty	Replace
Hot air flow rate reduced	Tangential fan faulty	Replace
	Obstructed inbound/outbound grate	Free
Fan not switching speed	Flame control board faulty	Replace
Burner not switching power	Chronothermostat faulty	Replace
	Faulty flame control board	Replace
	Gas valve faulty	Replace
	Faulty / wrong cabling	Replace / restore correctly
Vibrations between the combustion motor and the aluminium tube log	No vibration-proof sleeve	Assembly vibration-proof sleeve



ITALKERO S.r.l. . via Lumumba 2 . Zona Ind. Torrazzi . 41122 Modena . Italy . Tel +39 59 2550711 . FAX +39 059 4900500 . www.italkero.it

NOTA: Nel continuo perfezionamento del prodotto, le caratteristiche estetiche e dimensionali, i dati tecnici, gli equipaggiamenti e gli accessori, possono essere soggetti a variazione.

NOTE: Due to ongoing product upgrading, aesthetic and dimensional features, technical details, fittings and accessories could undergo changes and are not binding.

NOTE : En vue de l'amélioration continue des produits, les caractéristiques esthétiques et de taille, les données techniques, l'équipement et les accessoires peuvent être modifiés.

HINWEIS: Im Bestreben unsere Produkte kontinuierlich zu verbessern, können maßbezogene und ästhetische Eigenschaften, technische Daten, Ausrüstungen und Anlagen sowie Zubehörkomponenten Veränderungen unterworfen sein.